

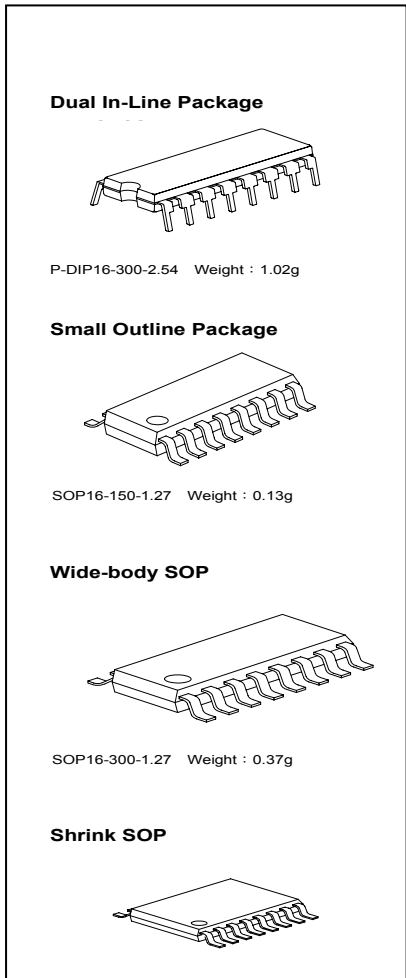

8-Bit Constant Current LED Driver with LED Error Detection and Run-Time Current Adjustment

Features

- Compatible with MBI5168 in electrical characteristics and package
- Exploiting **Share-I-O™** technique to provide two operation modes:
 - Normal Mode with the same functionality as MB5168
 - Special Mode to detect individual LED errors, like MBI5169 and program output current gain, like MBI5170
- 8 constant-current output channels
- Constant output current invariant to load voltage change
- Constant output current range: 5 -120 mA
- Excellent output current accuracy,
 - between channels: < ±3% (max.), and
 - between ICs: < ±6% (max.)
- Output current adjusted through an external resistor
- Fast response of output current,
 - \overline{OE} (min.): 200 ns @ $I_{out} < 60mA$
 - \overline{OE} (min.): 400 ns @ $I_{out} = 60\sim 100mA$
- 25MHz clock frequency
- Schmitt trigger input
- 3.3~ 5V supply voltage
- 256-step run-time programmable output current gain suitable for white balance application
- Optional for “Pb-free & Green” Package



Current Accuracy		Conditions
Between Channels	Between ICs	
< ±3%	< ±6%	$I_{OUT} = 10 \sim 100 \text{ mA}$, $V_{DS} = 0.8V, V_{DD} = 5.0V$

Product Description

MBI5171 succeeds MBI5168 and also exploits **PrecisionDrive™** technology to enhance its output characteristics. Furthermore, MBI5171 uses the idea of **Share-I-O™** technology to make MBI5171 backward compatible with MBI5168 in both package and electrical characteristics and extend its functionality for LED load Error Detection and run-time LED current gain control in LED display systems, especially LED traffic sign applications.

MBI5171 contains an 8-bit Shift Register and an 8-bit Output Latch, which convert serial input data into parallel output format. At MBI5171 output stages, eight regulated current ports are designed to provide uniform and constant current sinks with small skew between ports for driving LED's within a wide range of forward voltage (V_f) variations. Users may adjust the output current from 5 mA to 120 mA with an external resistor R_{ext} , which gives users flexibility in controlling the light intensity of LED's. MBI5171 guarantees to endure maximum 17V at the output ports. Besides, the high clock frequency up to 25 MHz also satisfies the system requirements of high volume data transmission.

MBI5171 extends its functionality to provide one Special Mode in which two functions are included, Error Detection and Current Gain Control, by means of the **Share-I-O™** technique on pins LE and \overline{OE} , without any extra pins. Thus, MBI5171 could be a drop-in replacement of MBI5168. The printed circuit board originally designed for MBI5168 may be also applied to MBI5171. In MBI5171 there are two operation modes and three phases: Normal Mode phase, Mode Switching transition phase, and Special Mode phase. The signal on the multiple function pin $\overline{OE}/\overline{SW}/\overline{ED}$ would be monitored. Once an one-clock-wide short pulse appears on the pin $\overline{OE}/\overline{SW}/\overline{ED}$, MBI5171 would enter the Mode Switching phase. At this moment, the voltage level on the pin LE/MOD/CA is used for determining the next mode to which MBI5171 is going to switch.

In the Normal Mode phase, MBI5171 has exactly the same functionality with MBI5168. The serial data could be transferred into MBI5171 via the pin SDI, shifted in the Shift Register, and go out via the pin SDO. The LE/MOD/CA can latch the serial data in the Shift Register to the Output Latch. $\overline{OE}/\overline{SW}/\overline{ED}$ would enable the output drivers to sink current.

In the Special Mode phase, the low-voltage-level signal $\overline{OE}/\overline{SW}/\overline{ED}$ can enable output channels and detect the status of the output current to tell if the driving current level is enough or not. The detected error status would be loaded into the 8-bit Shift Register and be shifted out via the pin SDO along with the signal CLK. Then system controller could read the error status and know whether the LED's are properly lit or not.

On the other hand, in the Special Mode phase MBI5171 also allows users to adjust the output current level by setting a run-time programmable Configuration Code. The code is sent into MBI5171 via the pin SDI. The positive pulse of LE/MOD/CA would latch the code in the Shift Register into a built-in 8-bit Configuration Latch, instead of the Output Latch. The code would affect the voltage at the terminal R-EXT and control the output current regulator. The output current could be adjusted finely by a gain ranging (1/12) to (127/128) in 256 steps. Hence, the current skew between IC's can be compensated within less than 1% and this feature is suitable for white balancing in LED color display panels.

Users can get detailed ideas about how MBI5171 works in the section **Operation Principle**.

Pin Assignment

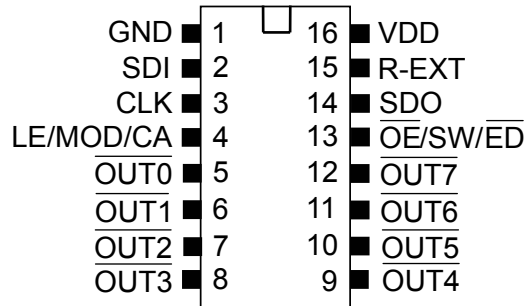

Terminal Description

Pin No.	Pin Name	Function
1	GND	Ground terminal for control logic and current sinks
2	SDI	Serial-data input to the Shift Register
3	CLK	Clock input terminal for data shift at the rising edge
4	LE/MOD/CA	<p>Output channel data strobe input terminal: in the Normal Mode phase, serial data in the Shift Register is transferred to the respective Output Latch when LE/MOD/CA is high; the data is latched inside the Output Latch when LE/MOD/CA goes low. If the data in the Output Latch is “1” (High), the respective output channel will be enabled after $\overline{OE/SW/ED}$ is pulled down to low.</p> <p>Mode selection input terminal: in the Mode Switching phase, LE/MOD/CA couldn't strobe serial data but its level is used for determining the next mode to which MBI5171 is going to switch. When LE/MOD/CA is high, the next mode is the Special Mode; when low, the next mode is the Normal Mode.</p> <p>Configuration data strobe input terminal: in the Special Mode phase, serial data is latched into the Configuration Latch, instead of the Output Latch in the Normal Mode. The serial data here is regarded as the Configuration Code, which affect the output current level of all channels.(See Operation Principle)</p>
5-12	$\overline{OUT0} \sim \overline{OUT7}$	Constant current output terminals
13	$\overline{OE/SW/ED}$	<p>Output enable terminal: no matter in what phase MBI5171 operates, the signal $\overline{OE/SW/ED}$ can always enable output drivers to sink current. When its level is (active) low, the output drivers are enabled; when high, all output drivers are turned OFF (blanked).</p> <p>Mode switching trigger terminal: an one-clock-wide short pulse signal of $\overline{OE/SW/ED}$ could put MBI5171 into the Mode Switching phase.</p> <p>Error detection enable terminal: in the Special Mode phase, the active low signal $\overline{OE/SW/ED}$ can make MBI5171 not just enable output drivers but detect LED load error status. The detected error status would be stored into the Shift Register. (See Operation Principle)</p>
14	SDO	Serial-data output to the following SDI of the next driver IC
15	R-EXT	Input terminal used for connecting an external resistor in order to set up the current level of all output ports
16	VDD	Supply voltage terminal

MBI5171

8-Bit Constant Current LED Driver with LED Error Detection and Run-Time Current Adjustment

In MBI5171, the relationship between the functions of pins 4 and 13 and the operation phases are listed below:

Pin No.	Pin Name	Function	Normal Mode	Mode Switching	Special Mode
4	LE/MOD/CA	LE: latching serial data into the Output Latch	Yes	No	No
		MOD: mode selection	No	Yes	No
		CA: latching serial data into the Configuration Latch	No	No	Yes
13	\overline{OE} / SW / \overline{ED}	\overline{OE} : enabling the current output drivers	Yes	Yes	Yes
		SW: entering the Mode Switching phase	Yes	Yes	Yes
		\overline{ED} : enabling error detection and storing results into the Shift Register	No	No	Yes

Block Diagram

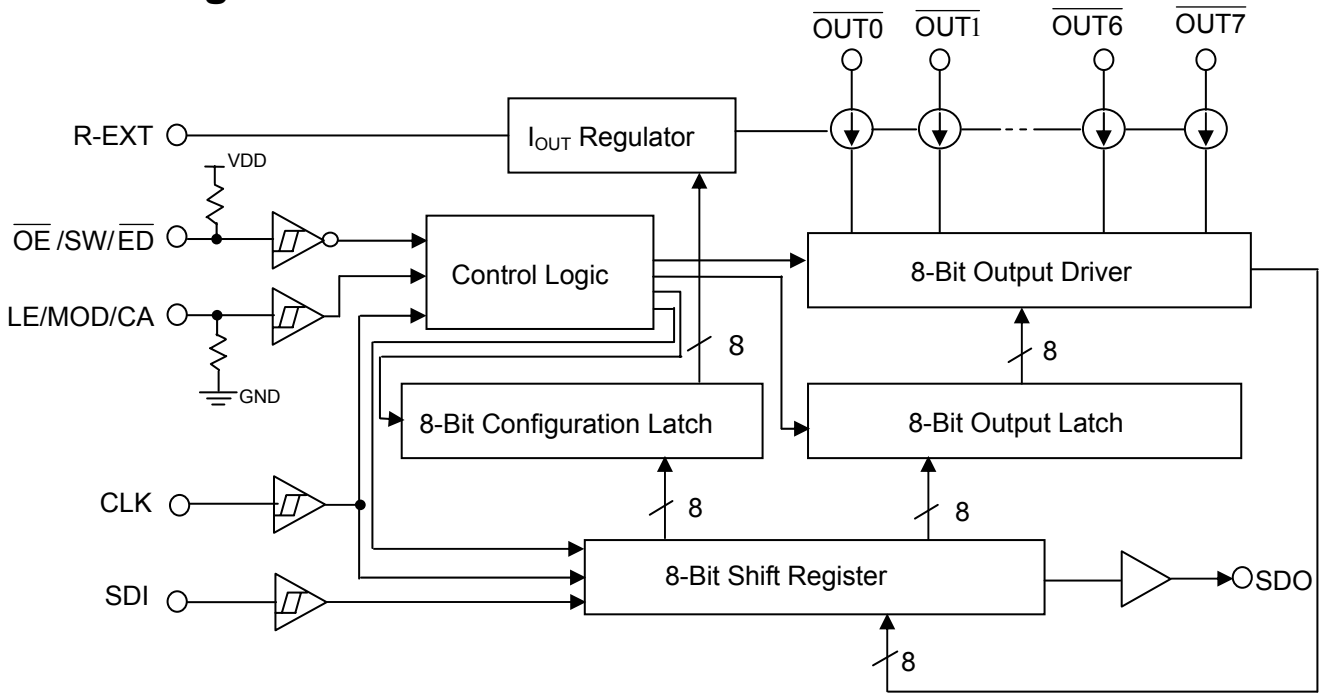

Equivalent Circuits of Inputs and Outputs

$\overline{OE}/SW/\overline{ED}$ Terminal

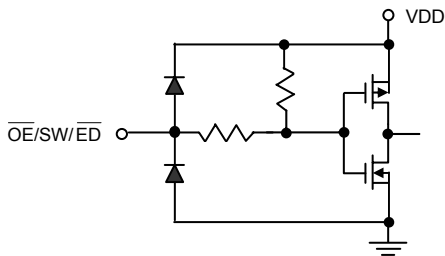

LE/MOD/CA Terminal

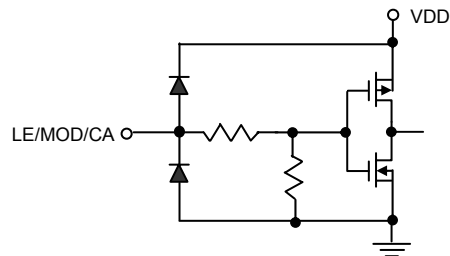

CLK, SDI Terminal

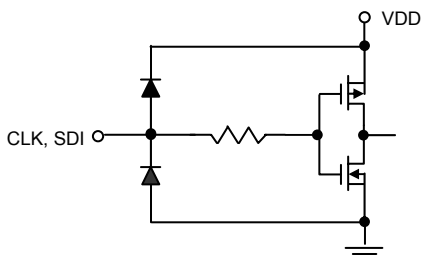

SDO Terminal

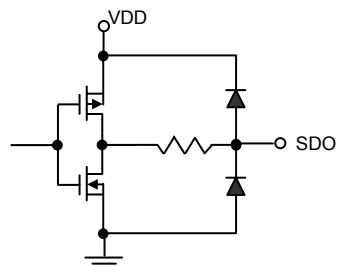

Timing Diagram

Normal Mode

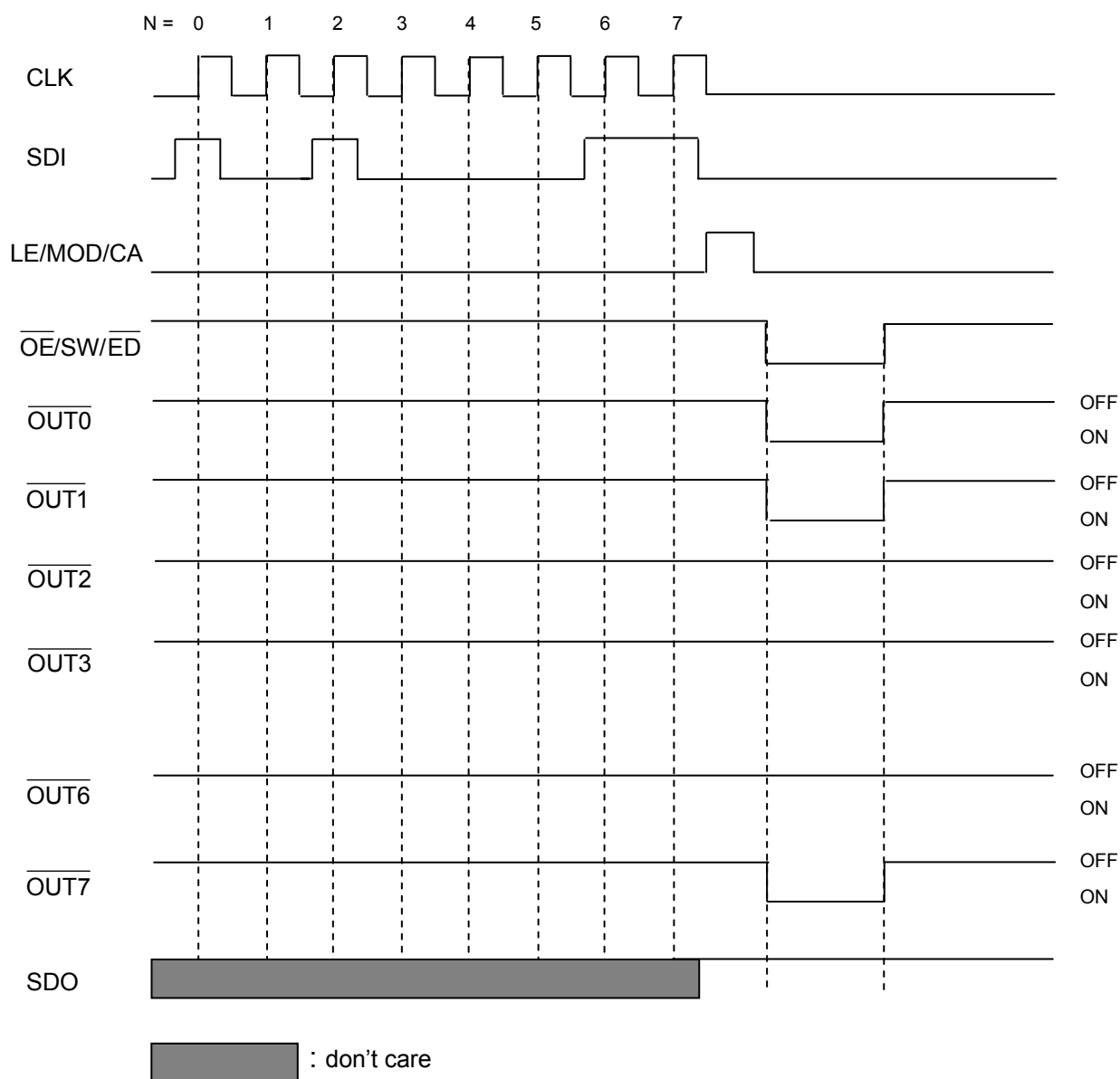

Truth Table (In Normal Mode)

CLK	LE/MOD/CA	OE/SW/ED	SDI	OUT0 ... OUT5 ... OUT7	SDO
	H	L	D_n	$\overline{D_n} \dots \overline{D_{n-5}} \dots \overline{D_{n-7}}$	D_{n-7}
	L	L	D_{n+1}	No Change	D_{n-6}
	H	L	D_{n+2}	$\overline{D_{n+2}} \dots \overline{D_{n-3}} \dots \overline{D_{n-5}}$	D_{n-5}
	X	L	D_{n+3}	$\overline{D_{n+2}} \dots \overline{D_{n-3}} \dots \overline{D_{n-5}}$	D_{n-5}
	X	H	D_{n+3}	Off	D_{n-5}

Switching to Special Mode

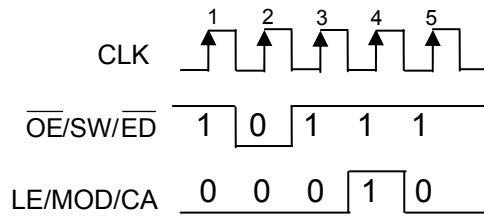

The above shows an example of the signal sequence that can set the next operation mode of MBI5171 to be the Special Mode. The LE/MOD/CA active pulse here would not latch any serial data.

Note:

After entering the Special Mode, MBI5171 can detect LED error and adjust current gain.

Writing Configuration Code (In Special Mode)

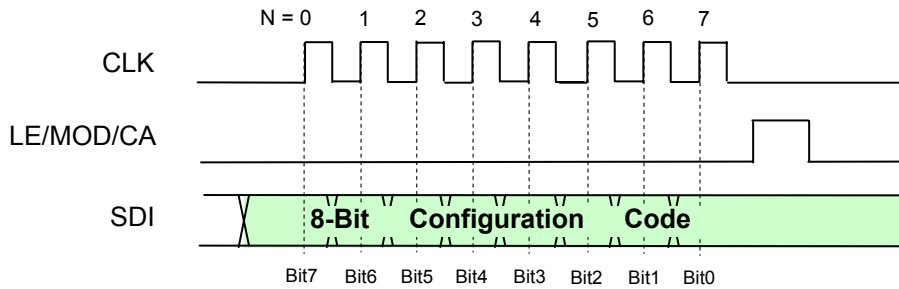

In the Special Mode, by sending the positive pulse of LE/MOD/CA, the content of the Shift Register with a Configuration Code will be written to the 8-bit Configuration Latch.

Reading Error Status Code (In Special Mode)

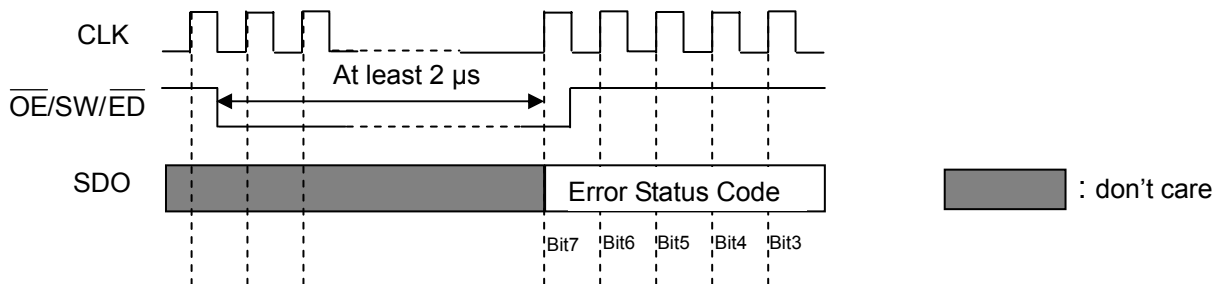

When MBI5171 is working in the Special Mode, the above signal sequence example can let a system controller read the Error Status codes via the pin SDO.

Switching to Normal Mode

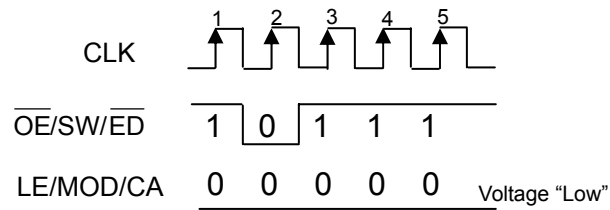

The above signal sequence example can make MBI5171 operate in the Normal Mode.

Note:

If users want to know the detailed process for each of the above examples, please refer to the contents in **Operation Principle**.

Maximum Ratings

Characteristics			Symbol	Rating	Unit	
Supply Voltage			V_{DD}	0 ~ 7.0	V	
Input Voltage			V_{IN}	-0.4 ~ $V_{DD} + 0.4$	V	
Output Current			I_{OUT}	+120	mA	
Output Voltage			V_{DS}	-0.5 ~ +20	V	
Clock Frequency			F_{CLK}	25	MHz	
GND Terminal Current			I_{GND}	1000	mA	
Power Dissipation (On PCB, $T_a=25^\circ\text{C}$)	CN	GN	P_D	1.55	1.66	W
	CD	GD		1.17	1.43	
	CDW	GDW		1.62	1.46	
	CP	GP		1.05	1.25	
Thermal Resistance (On PCB, $T_a=25^\circ\text{C}$)	CN	GN	$R_{th(j-a)}$	64.35	60.20	$^\circ\text{C/W}$
	CD	GD		85.82	70.14	
	CDW	GDW		61.63	68.67	
	CP	GP		94.91	80.00	
Operating Temperature			T_{opr}	-40 ~ +85	$^\circ\text{C}$	
Storage Temperature			T_{stg}	-55 ~ +150	$^\circ\text{C}$	

Recommended Operating Conditions

Characteristics	Symbol	Condition	Min.	Typ.	Max.	Unit
Supply Voltage	V_{DD}	-	4.5	5.0	5.5	V
Output Voltage	V_{DS}	$\overline{OUT0} \sim \overline{OUT7}$	-	-	17.0	V
Output Current	I_{OUT}	$\overline{OUT0} \sim \overline{OUT7}$ CM*=1, $V_{DD} = 5V$	5	-	120	mA
	I_{OUT}	$\overline{OUT0} \sim \overline{OUT7}$, CM*=0, $V_{DD} = 5V$	5	-	40	mA
	I_{OH}	SDO	-	-	-1.0	mA
	I_{OL}	SDO	-	-	1.0	mA
Input Voltage	V_{IH}	CLK, $\overline{OE}/\overline{SW}/\overline{ED}$ LE/MOD, and SDI	$0.7V_{DD}$	-	$V_{DD} + 0.3$	V
	V_{IL}	CLK, $\overline{OE}/\overline{SW}/\overline{ED}$, LE/MOD, and SDI	-0.3	-	$0.3V_{DD}$	V
CLK Pulse Width	$t_{w(CLK)}$	-	20	-	-	ns
Setup Time for SDI	$t_{su(D)}$		5	-	-	ns
Hold Time for SDI	$t_{h(D)}$		10	-	-	ns
LE/MOD/CA Pulse Width	$t_{w(L)}$		20	-	-	ns
Setup Time for LE/MOD/CA	$t_{su(L)}$	For data strobe	5	-	-	ns
Hold Time for LE/MOD/CA	$t_{h(L)}$		10	-	-	ns
Setup Time for LE/MOD/CA	$t_{su(MOD)}$	In Mode Switching	5	-	-	ns
Hold Time for LE/MOD/CA	$t_{h(MOD)}$		10	-	-	ns
$\overline{OE}/\overline{SW}/\overline{ED}$ Pulse Width	$t_{w(SW)}$	To trigger Mode Switching	20	-	-	ns
	$t_{w(OE)}$	$I_{out} < 60mA$	200	-	-	ns
	$t_{w(OE)}$	$I_{out} = 60 \sim 100mA$	400	-	-	ns
	$t_{w(ED)}$	When detecting LED error status	2010	-	-	ns
Setup Time for Correctly-Generated Error Status Code **	$t_{su(ER)}$	When detecting LED error status	2000	-	-	ns
Setup Time for $\overline{OE}/\overline{SW}/\overline{ED}$	$t_{su(SW)}$	To trigger Mode Switching or when detecting LED error status	5	-	-	ns
Hold Time for $\overline{OE}/\overline{SW}/\overline{ED}$	$t_{h(SW)}$		10	-	-	ns
Clock Frequency	F_{CLK}	Cascade Operation ($V_{DD} = 5.0V$)	-	-	25	MHz

* CM is one bit in configuration code and called as “Current Multiplier.” It would affect the ratio of I_{OUT} to $I_{r_{ext}}$. The detail information could be found in the section **Operation Principle**.

** In the Error Detection mode, when $\overline{OE}/\overline{SW}/\overline{ED}$ is pulled down to LOW for enabling output drivers and error detection, the output drivers must be enabled for at least 2us so that the error status code could be correctly generated. See **Operation Principle** and **Timing Waveform**.

Electrical Characteristics(V_{DD} = 5.0V)

Characteristics		Symbol	Condition	Min.	Typ.	Max.	Unit
Supply Voltage		V _{DD}	-	4.5	5.0	5.5	V
Output Voltage		V _{DS}	$\overline{\text{OUT0}} \sim \overline{\text{OUT7}}$	-	-	17.0	V
Output Current		I _{OUT}	Test Circuit for Electrical Characteristics	5	-	120	mA
		I _{OH}	SDO	-	-	-1.0	mA
		I _{OL}	SDO	-	-	1.0	mA
Input Voltage	“H” level	V _{IH}	Ta = -40~85°C	0.7V _{DD}	-	V _{DD}	V
	“L” level	V _{IL}	Ta = -40~85°C	GND	-	0.3V _{DD}	V
Output Leakage Current			V _{DS} =17.0V and channel off	-	-	0.5	µA
Output Voltage	SDO	V _{OL}	I _{OL} =+1.0mA	-	-	0.4	V
		V _{OH}	I _{OH} =-1.0mA	4.6	-	-	V
Output Current 1		I _{OUT1}	V _{DS} = 0.5V; R _{ext} = 744Ω; CG* = 0.992	-	25.0	-	mA
Current Skew (between channels)		dI _{OUT1}	I _{OUT} = 25mA, V _{DS} ≥ 0.5V	-	±1	±3	%
Output Current 2		I _{OUT2}	V _{DS} = 0.6V; R _{ext} = 372Ω; CG* = 0.992	-	50.0	-	mA
Current Skew (between channels)		dI _{OUT2}	I _{OUT} = 50mA, V _{DS} ≥ 0.6V	-	±1	±3	%
Output Current 3		I _{OUT3}	V _{DS} = 0.8V; R _{ext} = 186Ω; CG* = 0.992	-	100	-	mA
Current Skew (between channels)		dI _{OUT3}	I _{OUT} = 100mA, V _{DS} ≥ 0.8V	-	±1	±3	%
Output Current vs. Output Voltage Regulation		%/dV _{DS}	V _{DS} within 1.0V and 3.0V	-	±0.1	-	% / V
Output Current vs. Supply Voltage Regulation		%/dV _{DD}	V _{DD} within 4.5V and 5.5V	-	±1	-	% / V
Pull-up Resistance		R _{IN(up)}	$\overline{\text{OE}}/\overline{\text{SW}}/\overline{\text{ED}}$	250	500	800	KΩ
Pull-down Resistance		R _{IN(down)}	LE/MOD/CA	250	500	800	KΩ
Threshold Current for Error Detection**		I _{out, Th1}	R _{ext} =744 Ω, CG* = 0.992, I _{out, target} = 25mA	-	-	24.9	mA
		I _{out, Th2}	R _{ext} =372 Ω, CG* = 0.992, I _{out, target} = 50mA	-	-	40	mA
		I _{out, Th3}	R _{ext} =186 Ω, CG* = 0.992, I _{out, target} = 100mA	-	-	70	mA
Supply Current	“OFF”	I _{DD(off) 0}	R _{ext} =Open, $\overline{\text{OUT0}} \sim \overline{\text{OUT7}}$ =Off; CG= 0.992	-	2.85	3.65	mA
		I _{DD(off) 1}	R _{ext} =744 Ω, $\overline{\text{OUT0}} \sim \overline{\text{OUT7}}$ =Off; CG= 0.992	-	5.9	7.9	
		I _{DD(off) 2}	R _{ext} =372 Ω, $\overline{\text{OUT0}} \sim \overline{\text{OUT7}}$ =Off; CG= 0.992	-	8.7	10.7	
		I _{DD(off) 3}	R _{ext} =186 Ω, $\overline{\text{OUT0}} \sim \overline{\text{OUT7}}$ =Off; CG= 0.992	-	14.4	16.4	
	“ON”	I _{DD(on) 1}	R _{ext} =744 Ω, $\overline{\text{OUT0}} \sim \overline{\text{OUT7}}$ =On; CG= 0.992	-	5.8	7.8	
		I _{DD(on) 2}	R _{ext} =372 Ω, $\overline{\text{OUT0}} \sim \overline{\text{OUT7}}$ =On; CG= 0.992	-	8.7	10.7	
		I _{DD(on) 3}	R _{ext} =186 Ω, $\overline{\text{OUT0}} \sim \overline{\text{OUT7}}$ =On; CG= 0.992	-	13.5	15.5	

* In the above table, CG is the programmable current gain. The detail description could be found in the section

Operation Principle.

** To effectively detect the load open-circuit error at the output ports, MBI5171 has a built-in current detection circuit. The current detection circuit will detect the effective current $I_{out, effective}$ and compare it with the threshold current $I_{out, Th}$. If $I_{out, effective}$ is less than the threshold current $I_{out, Th}$, an error flag (LOW) will be asserted and stored into the built-in Shift Register. Each combination of external resistor R_{ext} and CG would determine a target output current $I_{out, target}$, which has a corresponding threshold current $I_{out, Th}$. To bias LED operation point properly and detect LED errors, there is a minimum effective output current requirement for each R_{ext} , such as $I_{out, Th1}$, $I_{out, Th2}$, and $I_{out, Th3}$.

Electrical Characteristics(V_{DD} = 3.3V)

Characteristics		Symbol	Condition	Min.	Typ.	Max.	Unit
Supply Voltage		V _{DD}	-	3.0	3.3	3.6	V
Output Voltage		V _{DS}	$\overline{\text{OUT0}} \sim \overline{\text{OUT7}}$	-	-	17.0	V
Output Current		I _{OUT}	Test Circuit for Electrical Characteristics	5	-	120	mA
		I _{OH}	SDO	-	-	-1.0	mA
		I _{OL}	SDO	-	-	1.0	mA
Input Voltage	“H” level	V _{IH}	Ta = -40~85°C	0.7V _{DD}	-	V _{DD}	V
	“L” level	V _{IL}	Ta = -40~85°C	GND	-	0.3V _{DD}	V
Output Leakage Current			V _{DS} =17.0V and channel off	-	-	0.5	μA
Output Voltage	SDO	V _{OL}	I _{OL} =+1.0mA	-	-	0.4	V
		V _{OH}	I _{OH} =-1.0mA	2.9	-	-	V
Output Current 1		I _{OUT1}	V _{DS} = 0.5V; R _{ext} = 744Ω; CG= 0.992	-	25.0	-	mA
Current Skew (between channels)		dI _{OUT1}	I _{OUT} = 25mA V _{DS} ≥ 0.5V	-	±1	±3	%
Output Current 2		I _{OUT2}	V _{DS} = 0.6V; R _{ext} = 372Ω; CG= 0.992	-	50.0	-	mA
Current Skew (between channels)		dI _{OUT2}	I _{OUT} = 50mA V _{DS} ≥ 0.6V	-	±1	±3	%
Output Current vs. Output Voltage Regulation		%/dV _{DS}	V _{DS} within 1.0V and 3.0V	-	±0.1	-	% / V
Output Current vs. Supply Voltage Regulation		%/dV _{DD}	V _{DD} within 3.2V and 3.6V	-	±1	-	% / V
Pull-up Resistance		R _{IN(up)}	$\overline{\text{OE}}/\text{SW}/\overline{\text{ED}}$	250	500	800	KΩ
Pull-down Resistance		R _{IN(down)}	LE/MOD/CA	250	500	800	KΩ
Threshold Current for Error Detection		I _{out, Th1}	R _{ext} =744 Ω, CG= 0.992, I _{out, target} = 25mA	-	-	24.9	mA
		I _{out, Th2}	R _{ext} =372 Ω, CG= 0.992, I _{out, target} = 50mA	-	-	40	mA
Supply Current	“OFF”	I _{DD(off) 0}	R _{ext} =Open, $\overline{\text{OUT0}} \sim \overline{\text{OUT7}}$ =Off, CG= 0.992	-	0.78	1.58	mA
		I _{DD(off) 1}	R _{ext} =744 Ω, $\overline{\text{OUT0}} \sim \overline{\text{OUT7}}$ =Off, CG= 0.992	-	3.6	4.4	
		I _{DD(off) 2}	R _{ext} =372 Ω, $\overline{\text{OUT0}} \sim \overline{\text{OUT7}}$ =Off, CG= 0.992	-	6.5	7.3	
	“ON”	I _{DD(on) 1}	R _{ext} =744 Ω, $\overline{\text{OUT0}} \sim \overline{\text{OUT7}}$ =On, CG= 0.992	-	3.6	4.2	
		I _{DD(on) 2}	R _{ext} =372 Ω, $\overline{\text{OUT0}} \sim \overline{\text{OUT7}}$ =On, CG= 0.992	-	6.4	7.2	

Switching Characteristics (V_{DD} = 5.0V)

Characteristics		Symbol	Condition	Min.	Typ.	Max.	Unit
Propagation Delay Time ("L" to "H")	CLK - $\overline{\text{OUTn}}$	t_{pLH1}	Test Circuit for Switching Characteristics $V_{DD}=5.0\text{ V}$ $V_{DS}=0.8\text{ V}$ $V_{IH}=V_{DD}$ $V_{IL}=GND$ $R_{ext}=372\ \Omega$ $V_L=4.0\text{ V}$ $R_L=64\ \Omega$ $C_L=10\text{ pF}$ $CG=0.992$	-	100	150	ns
	LE/MOD/CA - $\overline{\text{OUTn}}$	t_{pLH2}		-	100	150	ns
	$\overline{\text{OE/SW/ED}}$ - $\overline{\text{OUTn}}$	t_{pLH3}		-	100	150	ns
	CLK - SDO	t_{pLH}		20	25	30	ns
Propagation Delay Time ("H" to "L")	CLK - $\overline{\text{OUTn}}$	t_{pHL1}		-	100	150	ns
	LE/MOD/CA - $\overline{\text{OUTn}}$	t_{pHL2}		-	100	150	ns
	$\overline{\text{OE/SW/ED}}$ - $\overline{\text{OUTn}}$	t_{pHL3}		-	100	150	ns
	CLK - SDO	t_{pHL}		20	25	30	ns
Pulse Width	CLK	$t_w(\text{CLK})$		20	-	-	ns
	LE/MOD/CA	$t_w(L)$		20	-	-	ns
	$\overline{\text{OE/SW/ED}}$ (@ $I_{out} < 60\text{mA}$)	$t_w(\text{OE})$		200	-	-	ns
Hold Time for LE/MOD/CA		$t_h(L)$		10	-	-	ns
Setup Time for LE/MOD/CA		$t_{su}(L)$		5	-	-	ns
Maximum CLK Rise Time		t_r^*	-	-	500	ns	
Maximum CLK Fall Time		t_f^*	-	-	500	ns	
Output Rise Time of Vout (turn off)		t_{or}	-	120	150	ns	
Output Fall Time of Vout (turn on)		t_{of}	-	200	250	ns	
Clock Frequency		F_{CLK}	Cascade Operation	-	-	25.0	MHz

* If MBI5171 are connected in cascade and t_r or t_f is large, it may be critical to achieve the timing required for data transfer between two cascaded LED drivers MBI5171.

Switching Characteristics ($V_{DD} = 3.3V$)

Characteristics		Symbol	Condition	Min.	Typ.	Max.	Unit
Propagation Delay Time ("L" to "H")	CLK - \overline{OUTn}	t_{pLH1}	Test Circuit for Switching Characteristics $V_{DD}=3.3V$ $V_{DS}=0.8V$ $V_{IH}=V_{DD}$ $V_{IL}=GND$ $R_{ext}=372\Omega$ $V_L=4.0V$ $R_L=64\Omega$ $C_L=10pF$ $CG=0.992$	-	100	150	ns
	LE/MOD/CA - \overline{OUTn}	t_{pLH2}		-	100	150	ns
	$\overline{OE}/\overline{SW}/\overline{ED}$ - \overline{OUTn}	t_{pLH3}		-	100	150	ns
	CLK - SDO	t_{pLH}		45	55	65	ns
Propagation Delay Time ("H" to "L")	CLK - \overline{OUTn}	t_{pHL1}		-	130	200	ns
	LE/MOD/CA - \overline{OUTn}	t_{pHL2}		-	130	200	ns
	$\overline{OE}/\overline{SW}/\overline{ED}$ - \overline{OUTn}	t_{pHL3}		-	130	200	ns
	CLK - SDO	t_{pHL}		45	55	65	ns
Pulse Width	CLK	$t_{w(CLK)}$		20	-	-	ns
	LE/MOD/CA	$t_{w(L)}$		20	-	-	ns
	$\overline{OE}/\overline{SW}/\overline{ED}$ (@ $I_{out} < 60mA$)	$t_{w(OE)}$		200	-	-	ns
Hold Time for LE/MOD/CA		$t_{h(L)}$		10	-	-	ns
Setup Time for LE/MOD/CA		$t_{su(L)}$		5	-	-	ns
Maximum CLK Rise Time		t_r		-	-	500	ns
Maximum CLK Fall Time		t_f	-	-	500	ns	
Output Rise Time of Vout (turn off)		t_{or}	-	120	150	ns	
Output Fall Time of Vout (turn on)		t_{of}	-	200	400	ns	
Clock Frequency		F_{CLK}	Cascade Operation	-	-	12.0	MHz

Test Circuit for Electrical Characteristics

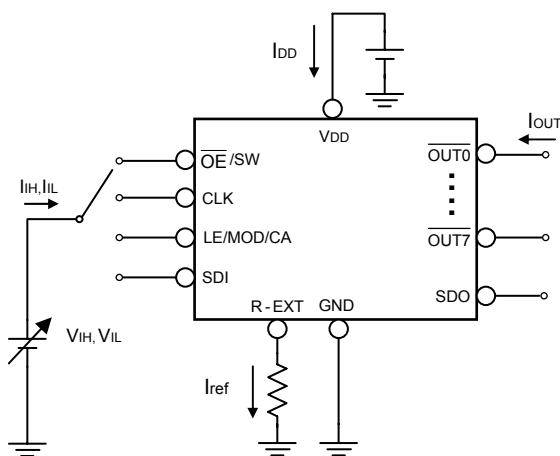

Test Circuit for Switching Characteristics

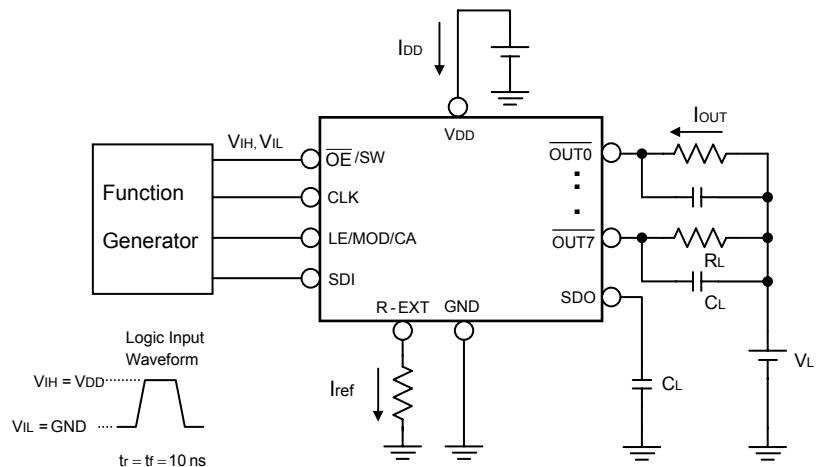

Timing Waveform

Normal Mode

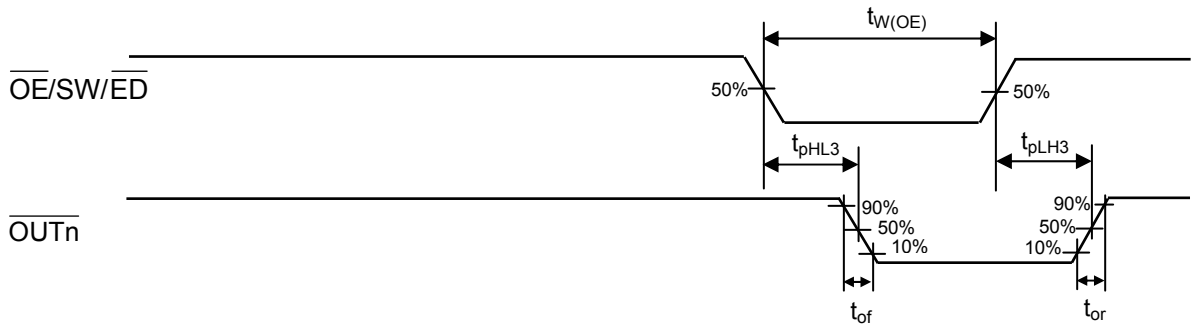
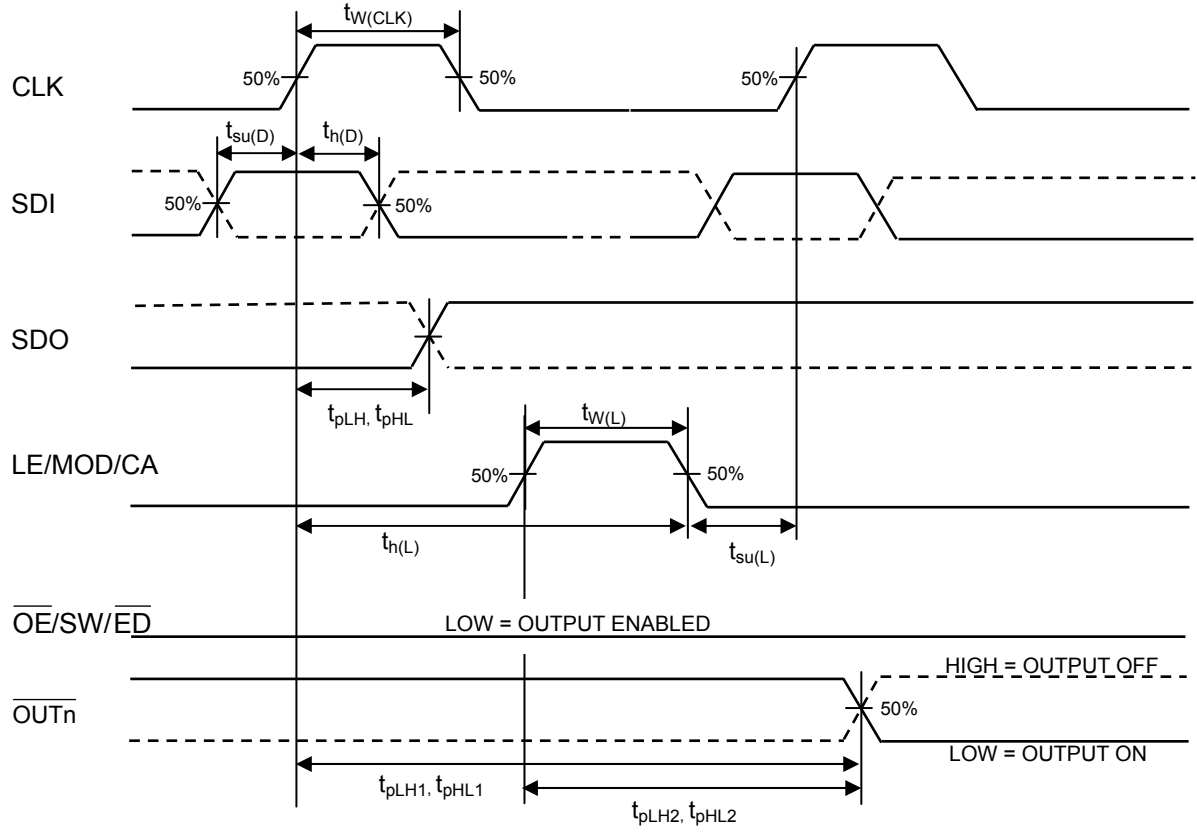

Switching to Special Mode

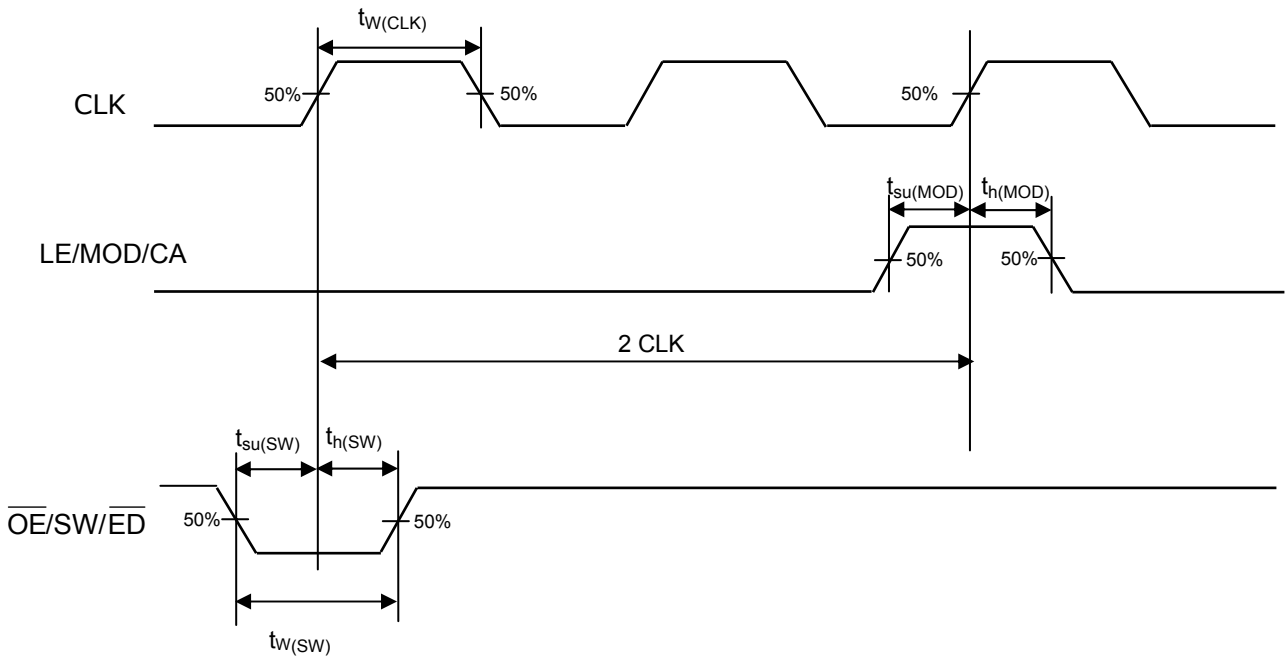

Reading Error Status Code

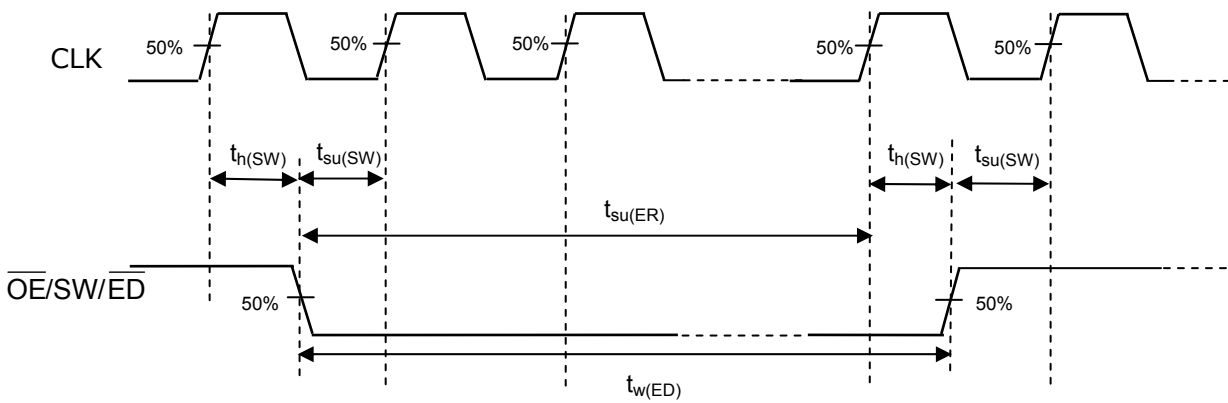

Operation Principle

Constant Current

In LED display applications, MBI5171 provides nearly no current variations from channel to channel and from IC to IC. This can be achieved by:

- 1) While $I_{OUT} \leq 100\text{mA}$, the maximum current skew between channels is less than $\pm 3\%$ and that between ICs is less than $\pm 6\%$.
- 2) In addition, the characteristics curve of output stage in the saturation region is flat as the figure shown below. Thus, the output current can be kept constant regardless of the variations of LED forward voltages (V_F). The output current in the saturation region is so flat that we define it as target current $I_{out, target}$.

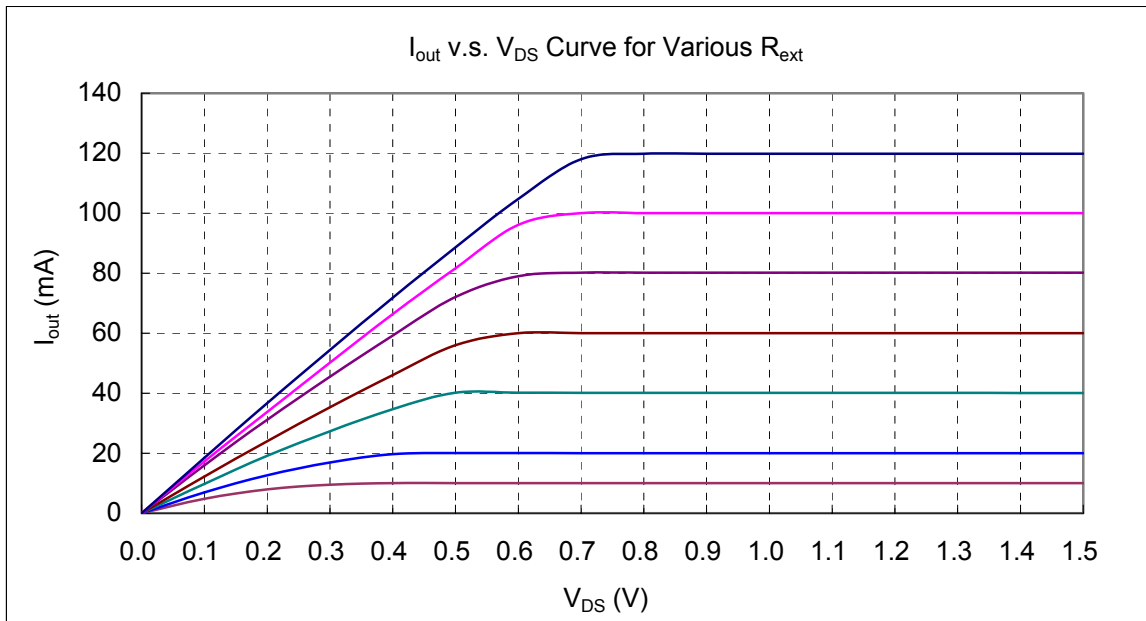

Adjusting Output Current

MBI5171 scales up the reference current I_{ref} set by the external resistor R_{ext} to sink a current I_{out} at each output port. Users can follow the below formulas to calculate the target output current $I_{out, target}$ in the saturation region:

$$V_{R-EXT} = 1.25\text{Volt} \times VG$$

$$I_{ref} = V_{R-EXT} / R_{ext} \quad \text{if another end of the external resistor } R_{ext} \text{ is connected to ground.}$$

$$I_{out, target} = I_{ref} \times 15 \times 3^{(CM-1)}$$

where R_{ext} is the resistance of the external resistor connected to the R-EXT terminal, and V_{R-EXT} is the voltage of the R-EXT terminal and controlled by the programmable voltage gain VG, which is defined by the Configuration Code. The Current Multiplier CM would determine that the ratio $I_{out, target}/I_{ref}$ is 15 or 5. After power-on, the default value of VG is $127/128 = 0.992$ and the default value of CM is 1, so that the ratio $I_{out, target}/I_{ref}$ is 15. Based on the default VG and CM,

$$V_{R-EXT} = 1.25\text{Volt} \times 127/128 = 1.24\text{Volt}$$

$$I_{out, target} = (1.24\text{Volt} / R_{ext}) \times 15$$

Hence, the default magnitude of current is around 50mA at 372Ω and 25mA at 744Ω. The default relationship after power-on between $I_{out, target}$ and R_{ext} is shown in the following figure.

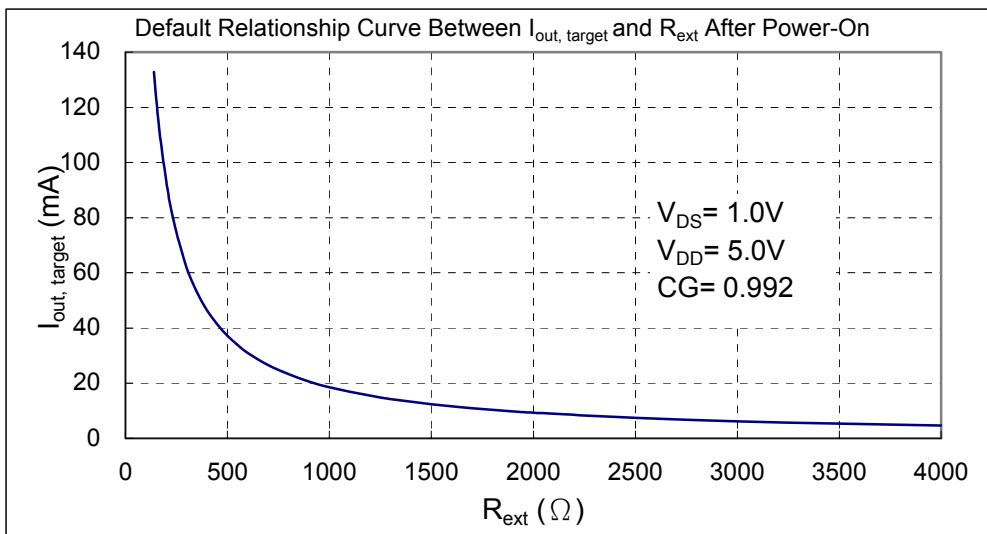

Operation Phases

MBI5171 exploits the **Share-I-O™** technique to extend the functionality of pins in MBI5168 in order to provide LED load error detection and run-time programmable LED driving current in the Special Mode phase as well as the original function of MBI5168 in the Normal Mode phase. In order to switch between the two modes, MBI5171 monitors the signal $\overline{OE/SW/ED}$. Once an one-clock-wide pulse of $\overline{OE/SW/ED}$ appears, MBI5171 would enter the two-clock-period transition phase--the Mode Switching phase. After power-on, the default operation mode is the Normal Mode.

Operation Mode Switching

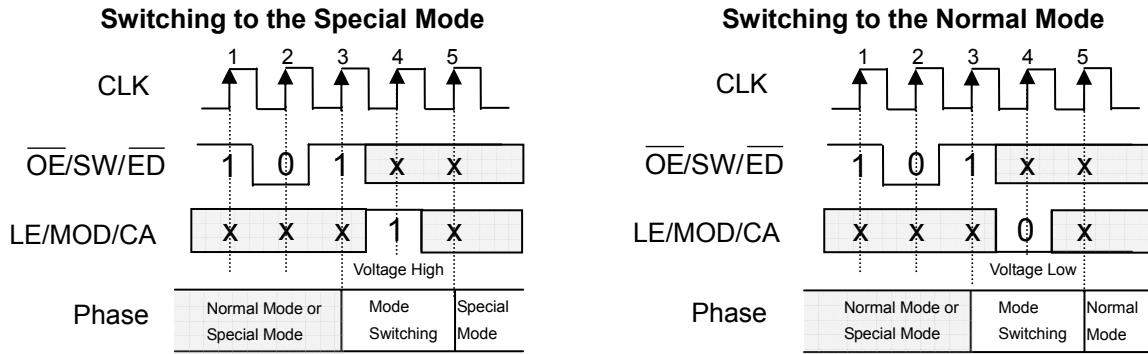

As shown in the above figures, once a one-clock-wide short pulse “101” of $\overline{OE/SW/ED}$ appears, MBI5171 would enter the Mode Switching phase. At the 4th rising edge of CLK, if LE/MOD/CA is sampled as “Voltage High”, MBI5171 would switch to the Special Mode; otherwise, it would switch to the Normal Mode. Worthwhile noticing, the signal LE/MOD/CA between the 3rd and the 5th rising edges of CLK can not latch any data. Its level is just used for determining which mode to switch. However, the short pulse of $\overline{OE/SW/ED}$ can still enable the output ports. During the mode switching, the serial data can still be transferred through the pin SDI and shifted out from the pin SDO.

Note:

1. The signal sequence for the mode switching could be frequently used for making sure under which mode MBI5171 is working.
2. The aforementioned “1” and “0” are sampled at the rising edge of CLK. The “X” means its level would not affect the result of mode switching mechanism.

Normal Mode Phase

MBI5171 in the Normal Mode phase has similar functionality to MBI5168. The serial data could be transferred into MBI5171 via the pin SDI, shifted in the Shift Register, and go out via the pin SDO. The LE/MOD/CA can latch the serial data in the Shift Register to the Output Latch. $\overline{OE/SW/ED}$ would enable the output drivers to sink current. The only difference is mentioned in the last paragraph about monitoring short pulse $\overline{OE/SW/ED}$. The short pulse would trigger MBI5171 to switch the operation mode. However, as long as the signal LE/MOD/CA is not Voltage High in the Mode Switching phase, MBI5171 would still remain in the Normal Mode as if no mode switching occurs.

Special Mode Phase

In the Special Mode, as long as $\overline{OE}/\overline{SW}/\overline{ED}$ is not at the Voltage Low, the serial data can still be shifted to the Shift Register via the pin SDI and shifted out via the SDO pin, as in the Normal Mode. But there are two differences between the Special Mode and the Normal Mode.

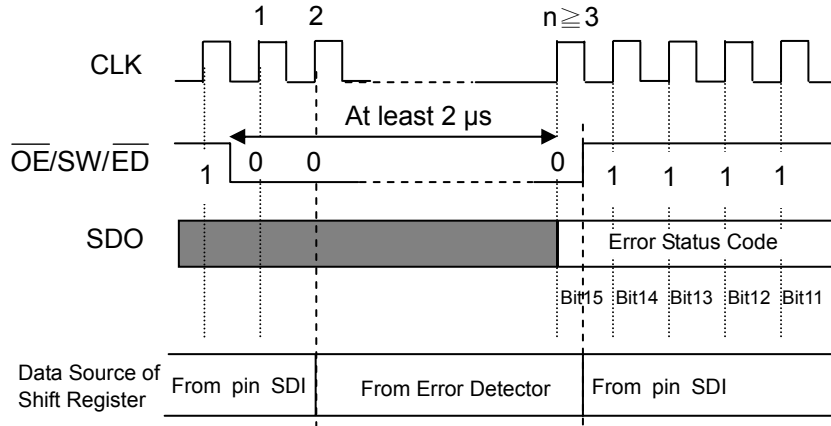

Reading Error Status Code (in Special Mode)

The first difference is that when the state of $\overline{OE}/\overline{SW}/\overline{ED}$ is pulled down to Voltage Low, MBI5171 in the Special Mode would execute error detection and load error status codes into the Shift Register, as well as enabling output ports to sink current. The above figure shows the timing sequence for error detection. The shown “0” and “1” are sampled at the rising edge of each CLK. At least three “0” must be sampled at the Voltage Low signal $\overline{OE}/\overline{SW}/\overline{ED}$. Just after the 2nd “0” is sampled, the data input source of the Shift Register would come from 8-bit parallel error status codes out of the circuit Error Detector, instead of serial data via the pin SDI. Normally, the error status codes will be correctly generated at least 2μs after the falling edge of $\overline{OE}/\overline{SW}/\overline{ED}$. The occurrence of the 3rd or later “0” results in the event that MBI5171 saves the detected error status codes into the Shift Register. Thus, when $\overline{OE}/\overline{SW}/\overline{ED}$ is at the Voltage Low state, the serial data cannot be shifted into MBI5171 via the pin SDI. But when the state of $\overline{OE}/\overline{SW}/\overline{ED}$ is pulled up to Voltage High from Voltage Low, the data input source of the Shift Register would again come from the pin SDI. At the same time, the output ports are disabled and the error detection is completed. Then, the error status codes saved in the Shift Register could be shifted out via the pin SDO bit by bit along with CLK, as well as the new serial data can be shifted into MBI5171 via the pin SDI. The limitation is that in the Special Mode, it couldn’t be allowed to **simultaneously** transfer serial data and detect LED load error status.

Writing Configuration Code (in Special Mode)

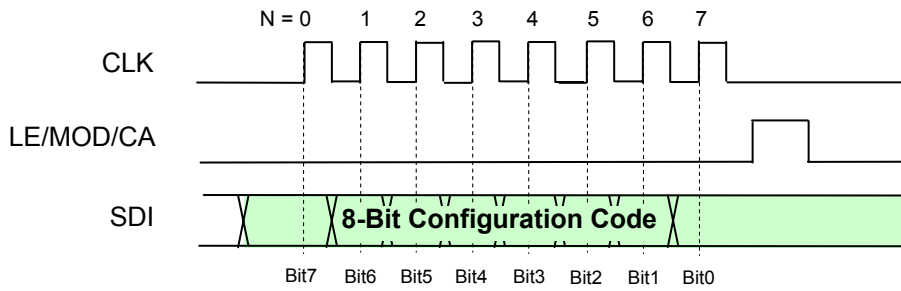

The second difference is that the active high signal LE/MOD/CA latches the serial data in the Shift Register to the Configuration Latch, instead of the Output Latch. The latched serial data is regarded as the Configuration Code. The code would be memorized until power off or the Configuration Latch is re-written. As shown above, the timing for writing the Configuration Code is the same as that in the Normal Mode for latching output channel data. As aforementioned descriptions, both of Configuration Code and Error Status Code are transferred in common 8-bit Shift Register. Users must pay attention to the sequence of error detection and current adjustment to avoid the Configuration Code being overwritten by Error Status Code.

Open-Circuit Detection Principle

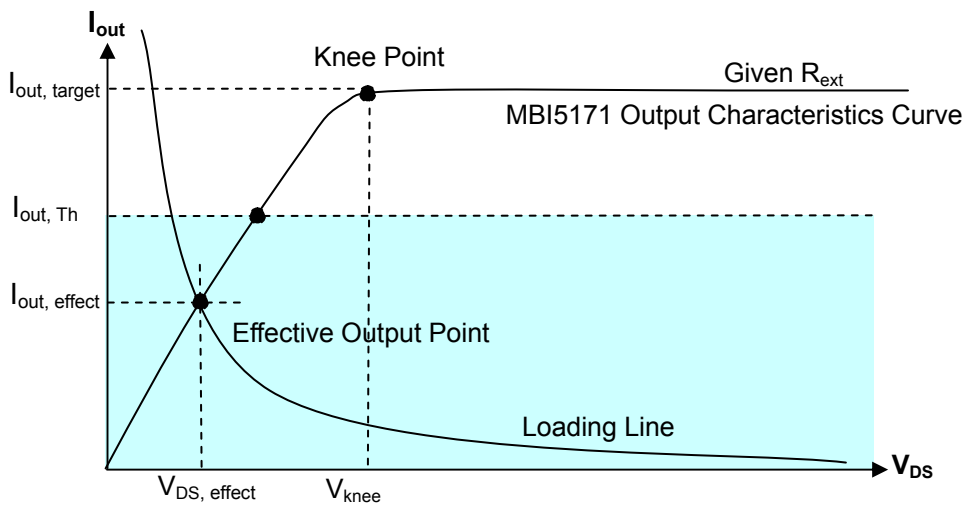

The principle of MBI5171 LED Open-Circuit Detection is based on the comparison between the effective current level $I_{out, effect}$ of each output port and the threshold current $I_{out, Th}$ corresponding to $I_{out, target}$. The cross point between the **Loading Line** and **MBI5171 Output Characteristics Curve** is called as effective output point ($V_{DS, effect}$, $I_{out, effect}$). If LED fails, due to open circuit, the **Loading Line** and the effective output point would change. Then, MBI5171 would catch the error status. But if the port is disabled, the output current would be absolutely 0mA and MBI5171 could not distinguish the change of the **Loading Line**. Thus, to detect the status of LED correctly, the output ports must be enabled. The relationship between the detected Error Status code and the position of the effective output point is shown in the following table.

State of Output Port	Condition of Effective Output Point	Detected Open-Circuit Error Status Code	Meaning
OFF	$I_{out, effect} = 0mA \ll I_{out, Th}$	"0"	-
ON	$I_{out, effect} < I_{out, Th}$	"0"	Open Circuit
	$I_{out, effect} \geq I_{out, Th}$	"1"	Normal

Note : As $I_{out, target} \geq 25mA$, the threshold current $I_{out, Th} = I_{out, target} \times 0.6 + 10mA$

As $I_{out, target} < 25mA$, the threshold current $I_{out, Th} = I_{out, target}$

Because the target current $I_{out, target}$ in the saturation region set by the external resistor R_{ext} and CG is a little bigger than the corresponding threshold current $I_{out, Th}$ for error detection, system design engineers had better place the effective output point of normal LED load in the saturation region after the knee point, for instance, if they want to detect the LED open error. Then while LED is open, the effective output point would move to the origin, where $I_{out} = 0mA$. So, MBI5171 can distinguish and detect it and report an error status codes "0".

In fact, if LED's are normal, the enabled ports would report error status codes "1" and the disabled would report "0". The error status codes are the same as the content in the Output Latch.

Short-Circuit Detection Principle

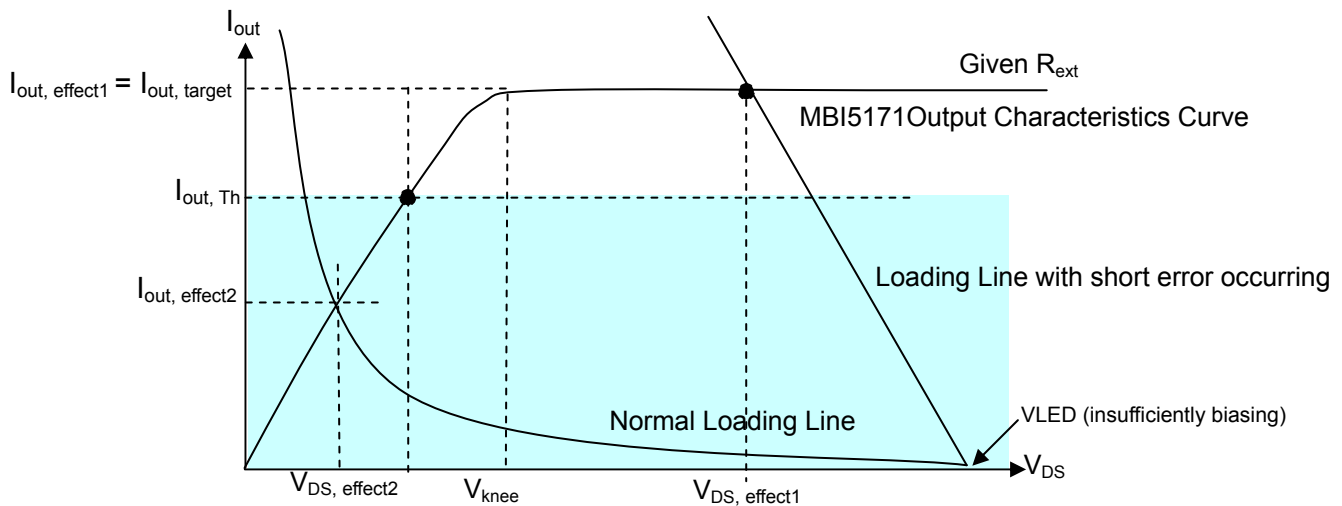

When LED is damaged, a short-circuit error may occur. To effectively detect the short-circuit error, LEDs need insufficient biasing. The principle of MBI5171 LED Short Circuit Detection is based on the fact that the LED loading status is judged by comparing the effective current value ($I_{out, effect}$) of each output port with the threshold current ($I_{out, Th}$). When normal LED is insufficiently biased, its effective output point would be located at the segment $I_{out, effect} < I_{out, Th}$ of MBI5171 Output Characteristics Curve, compared with LED with a short error falling within the segment $I_{out, effect} > I_{out, Th}$. The relationship between the Error Status code and the effective output point is shown below:

State of Output Port	Condition of Effective Output Point	Detected Short-Circuit Error Status Code	Meaning
OFF	$I_{out, effect} = 0$	"0"	-
ON	$I_{out, effect} < I_{out, Th}$	"0"	Normal
	$I_{out, effect} \geq I_{out, Th}$	"1"	Short Circuit

8-Bit Configuration Code and Current Gain CG

Bit Definition of 8-Bit Configuration Code								
	Bit 0	Bit 1	Bit 2	Bit 3	Bit 4	Bit 5	Bit 6	Bit 7
Meaning	CM	HC	CC0	CC1	CC2	CC3	CC4	CC5
Default Value	1	1	1	1	1	1	1	1

Bit definition of the Configuration Code in the Configuration Latch is shown above. Bit 7 is first sent into MBI5171 via the pin SDI. Bit 1 ~ 7, {HC, CC[0:5]}, would determine the voltage gain (VG), that affects the voltage at R-EXT terminal and indirectly the reference current I_{ref} flowing through the external resistor at terminal R-EXT. Bit 0 is the Current Multiplier (CM) bit, that determines the ratio $I_{out, target}/I_{ref}$. Each combination of VG and CM would give a Current Gain (CG).

- VG: the relationship between {HC, CC[0:5]} and the Voltage Gain VG can be formulated as below:

$$VG = (1 + HC) \times (1 + D/64) / 4$$

$$D = CC0 \times 2^5 + CC1 \times 2^4 + CC2 \times 2^3 + CC3 \times 2^2 + CC4 \times 2^1 + CC5 \times 2^0$$

where HC is 1 or 0, and D is the binary value of CC[0:5]. So, the VG could be regarded as a floating-point number with one bit exponent HC and 6-bit mantissa CC[0:5]. {HC, CC[0:5]} divides the programmable voltage gain VG into 128 steps and two sub-bands:

Low voltage sub-band (HC=0): $VG = 1/4 \sim 127/256$, linearly divided into 64 steps;

High voltage sub-band (HC=1): $VG = 1/2 \sim 127/128$, linearly divided into 64 steps, too.
- CM: as well as determining the ratio $I_{out, target}/I_{ref}$, the CM bit would limit the output current range.

High Current Multiplier (CM=1): $I_{out, target}/I_{ref} = 15$ and suitable for output current range $I_{out} = 10 \sim 120mA$.

Low Current Multiplier (CM=0): $I_{out, target}/I_{ref} = 5$ and suitable for output current range $I_{out} = 5 \sim 40mA$.
- CG: the total Current Gain is defined as the following.

$$V_{R-EXT} = 1.25Volt \times VG$$

$$I_{ref} = V_{R-EXT} / R_{ext} \quad \text{if another end of the external resistor } R_{ext} \text{ is connected to ground.}$$

$$I_{out, target} = I_{ref} \times 15 \times 3^{(CM-1)} = 1.25Volt / R_{ext} \times VG \times 15 \times 3^{(CM-1)} = (1.25Volt / R_{ext} \times 15) \times CG$$

We define $CG = VG \times 3^{(CM-1)}$. Hence $CG = (1/12) \sim (127/128)$ and it is divided into 256 steps, totally. If $CG = 127/128 = 0.992$, the $I_{out, target}-R_{ext}$ relationship is similar to that in MBI5168.

For example,

- When the Configuration Code {CM, HC, CC[0:5]} = {1,1,111111},
 $VG = 127/128 = 0.992$; and $CG = VG \times 3^0 = VG = 0.992$
- When the Configuration Code is {1,1,000000},
 $VG = (1+1) \times (1+0/64)/4 = 1/2 = 0.5$; and $CG = 0.5$
- When the Configuration Code is {0,0,000000},
 $VG = (1+0) \times (1+0/64)/4 = 1/4$; and $CG = (1/4) \times 3^{-1} = 1/12$

After power on, the default value of the Configuration Code {CM, HC, CC[0:5]} is {1,1,111111}. Thus, $VG = CG = 0.992$. The relationship between the Configuration Code and the Current Gain CG is shown in the following.

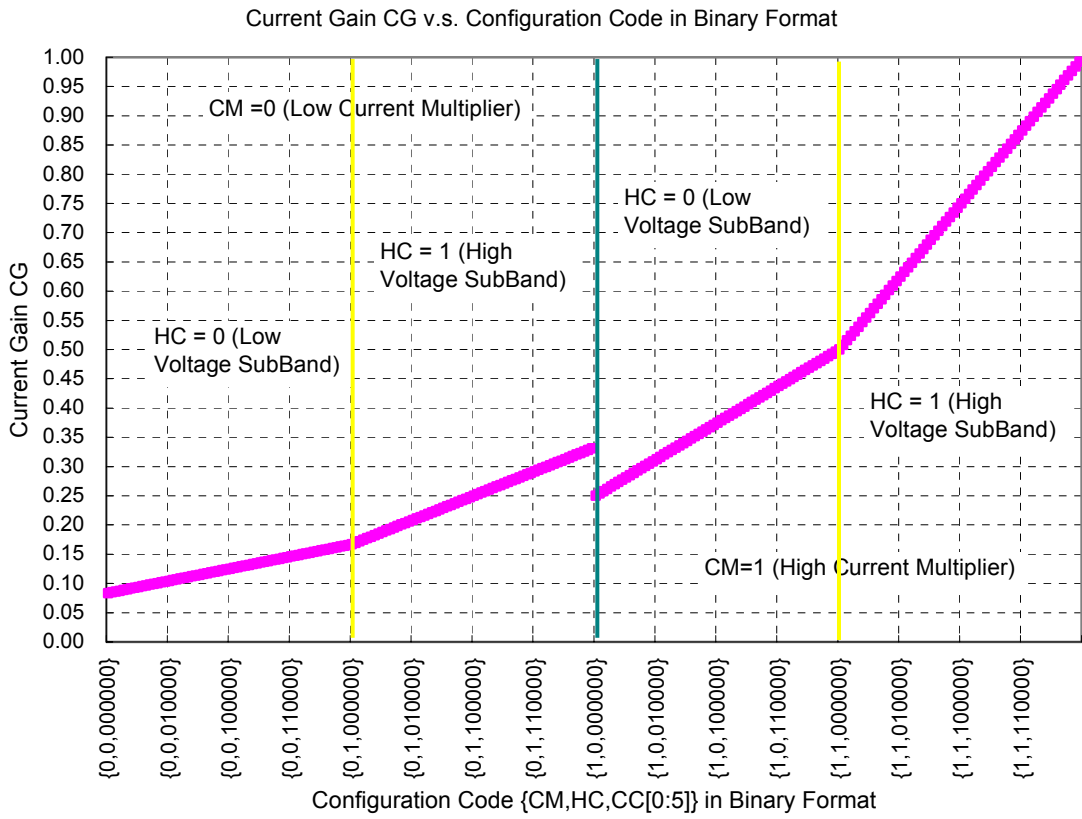

Timing Chart for Current Adjustment

N of MBI5171 are connected in cascade, i.e., SDO, k --> SDI, k+1.
And, all MBI5171 are connected to the same signal bus CLK, LE/MOD/CA and $\overline{OE}/\overline{SW}/\overline{ED}$.

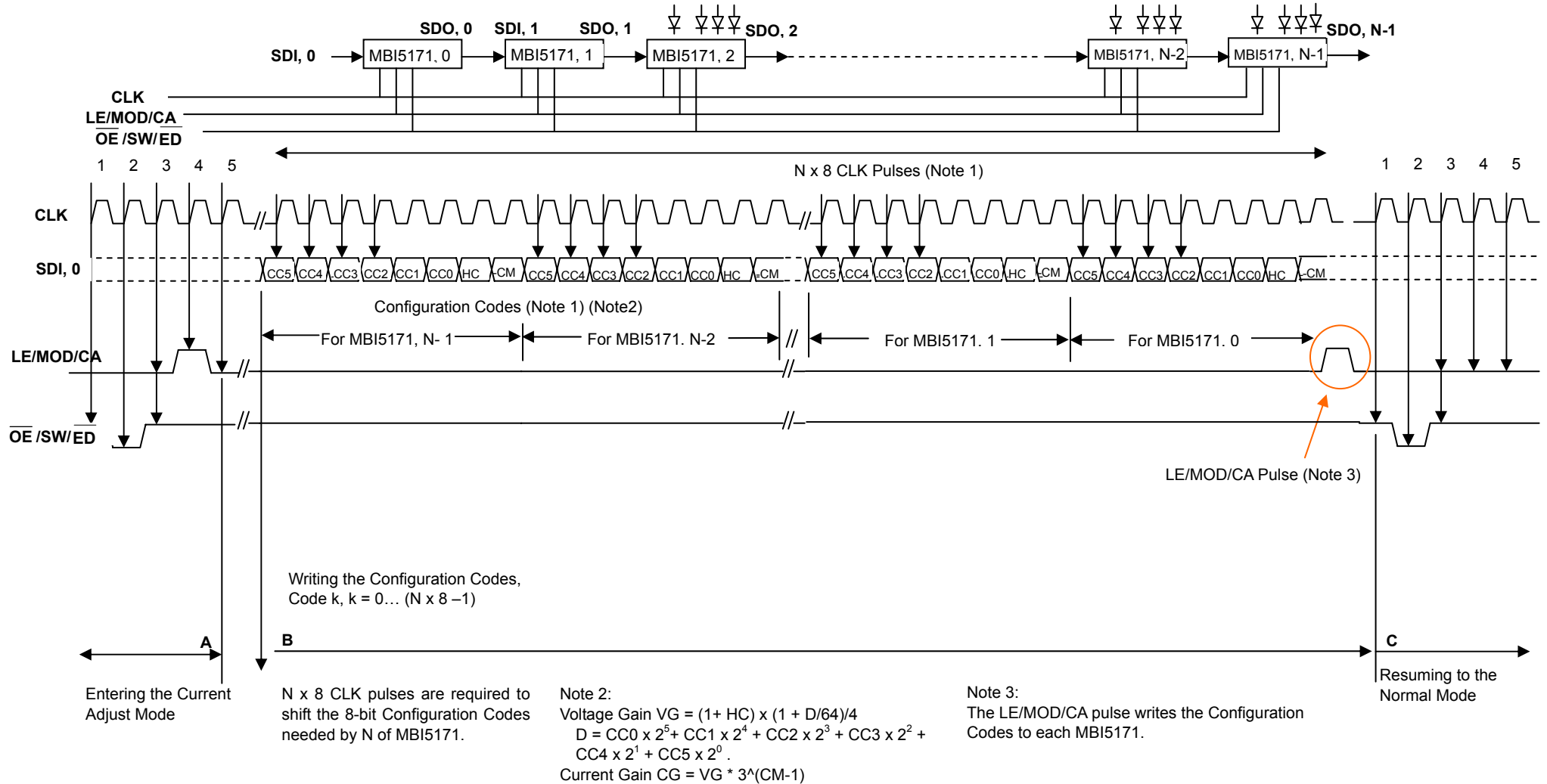

Timing Chart for Detecting LED Error

The connection of each MBI5171 is referred to "Timing Chart for Current Adjustment", shown on P26.

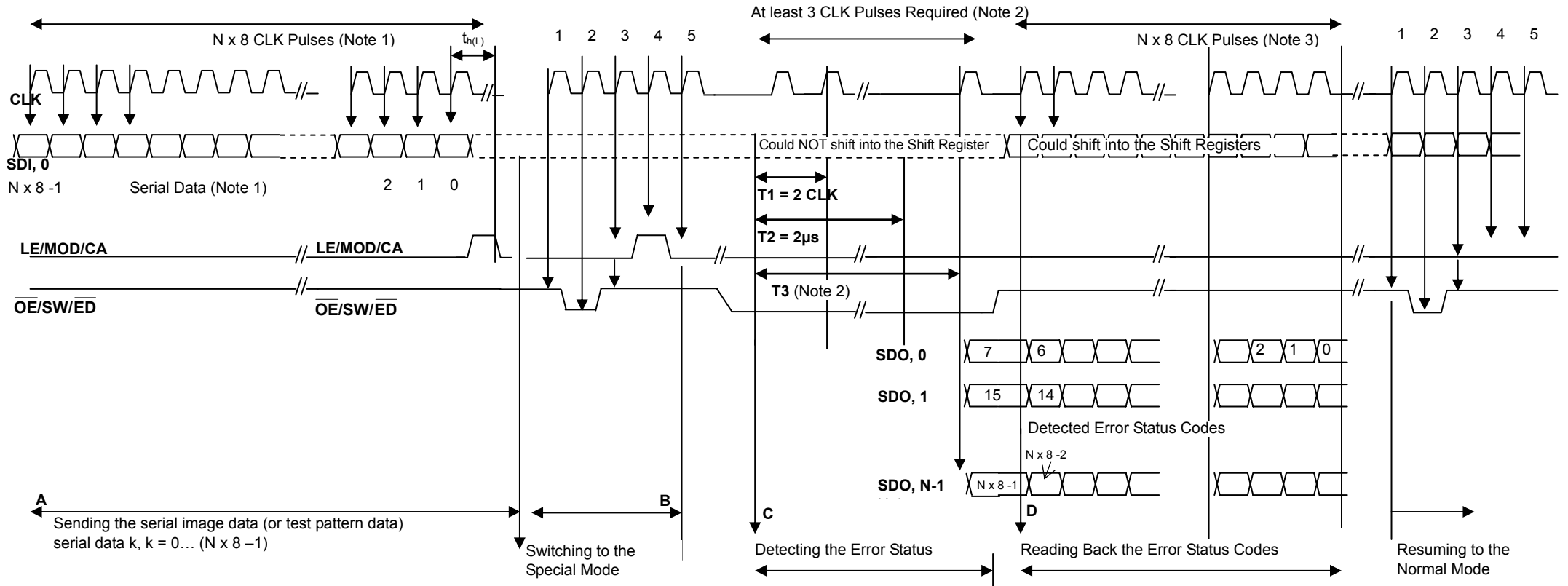

Note 2:
 T1 = 2 CLK pluses are required to change input of Shift Register. And, when Short-Circuit Detection is executed, LEDs should be insufficiently biased during this period.
 T2 = 2 μs is required to obtain the stable error status result.
 T3 = the third CLK pulses is required before OE/SW/ED goes Voltage High. The rising edge of CLK writes the error status codes back to the MBI5171 built-in Shift Register.

Note 1:
 N x 8 CLK pulses are required to shift the serial image data N x 8 bits needed by N of MBI5171.

Note 3:
 The rising edge of CLK after the rising edge of OE/SW/ED would shift the new serial image data and error codes. An LED error will be represented by a "0", to overwrite the original image data "1". Image Data k, k = 0... (N x 8 - 1), = all "1" is suggested.
 N x 8 CLK pulses shift all N x 8 error results (Error Status Code) via Node SDO, N-1.

Application Information

Soldering Process of “Pb-free & Green” Package Plating*

Macroblock has defines "Pb-Free & Green" to mean semiconductor products that are compatible with the current RoHS requirements and selected **100% pure tin** (Sn) to provide forward and backward compatibility with both the current industry-standard SnPb-based soldering processes and higher-temperature Pb-free processes. Pure tin is widely accepted by customers and suppliers of electronic devices in Europe, Asia and the US as the lead-free surface finish of choice to replace tin-lead. Also, it is backward compatible to standard 215°C to 240°C reflow processes which adopt tin/lead (SnPb) solder paste. However, in the whole Pb-free soldering processes and materials, 100% pure tin (Sn), will all require up to 260°C for proper soldering on boards, referring to J-STD-020B as shown below.

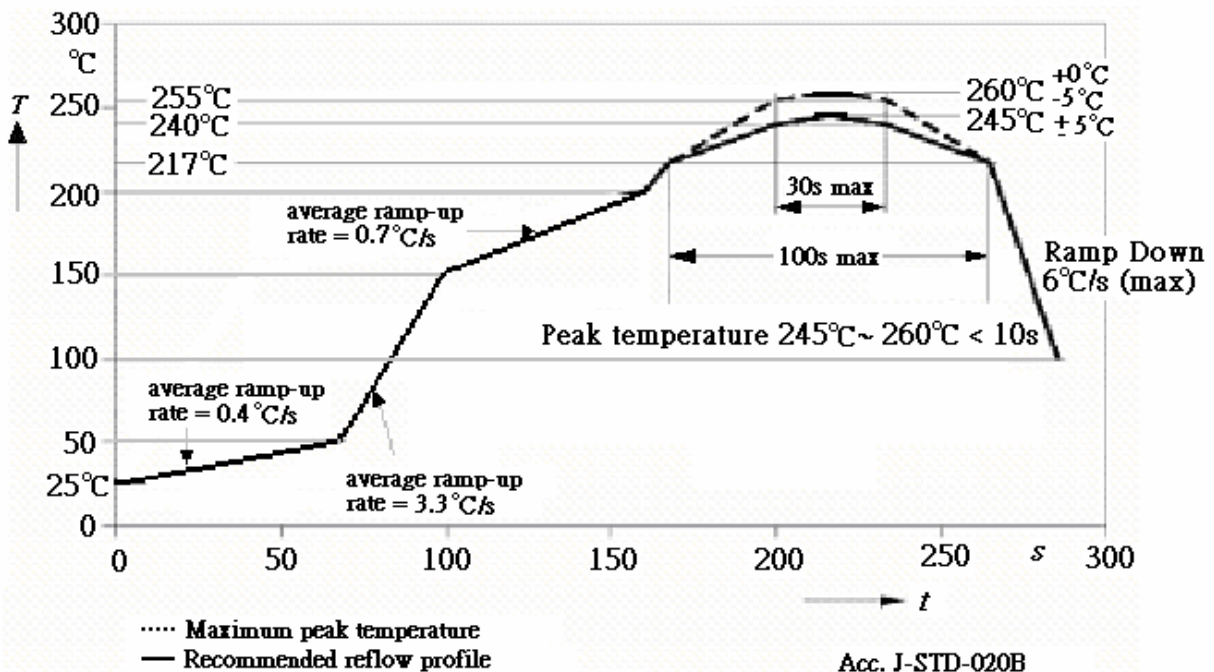

*Note1: For details, please refer to Macroblock’s “Policy on Pb-free & Green Package”.

8-Bit Constant Current LED Sink Driver with LED Error Detection and Run-Time Current Adjustment

MBI5171

Package Power Dissipation (P_D)

The maximum allowable package power dissipation is determined as $P_{D(max)} = (T_j - T_a) / R_{th(j-a)}$. When 8 output channels are turned on simultaneously, the actual package power dissipation is

$$P_{D(act)} = (I_{DD} \times V_{DD}) + (I_{OUT} \times Duty \times V_{DS} \times 8)$$

Therefore, to keep $P_{D(act)} \leq P_{D(max)}$, the allowable maximum output current as a function of duty cycle is

$$I_{OUT} = \{ [(T_j - T_a) / R_{th(j-a)}] - (I_{DD} \times V_{DD}) \} / V_{DS} / Duty / 8$$

where $T_j = 150^\circ\text{C}$.

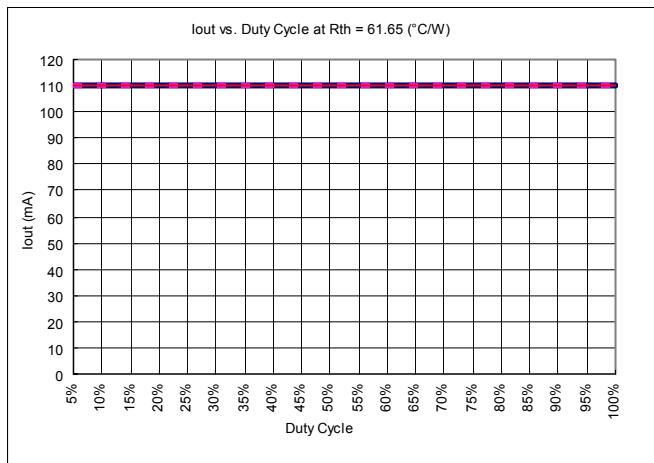

CN\GN Device Type

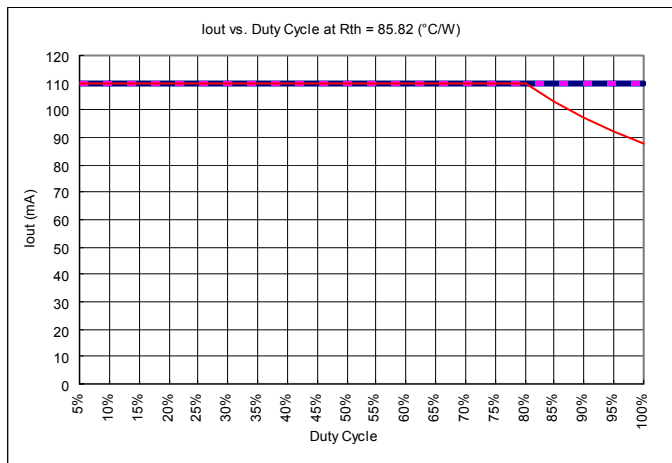

CD\GD Device Type

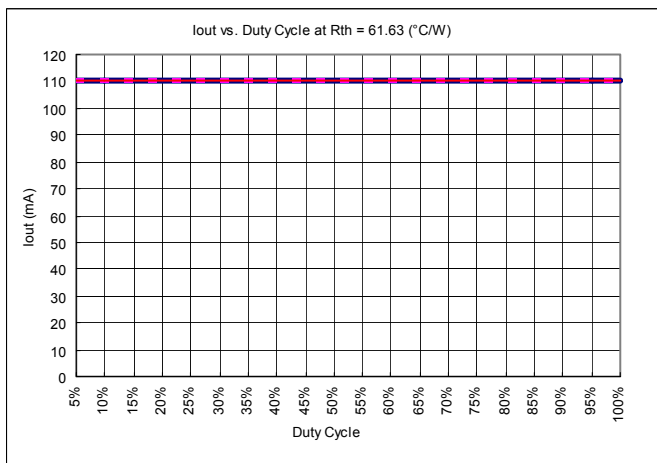

CDW\GDW Device

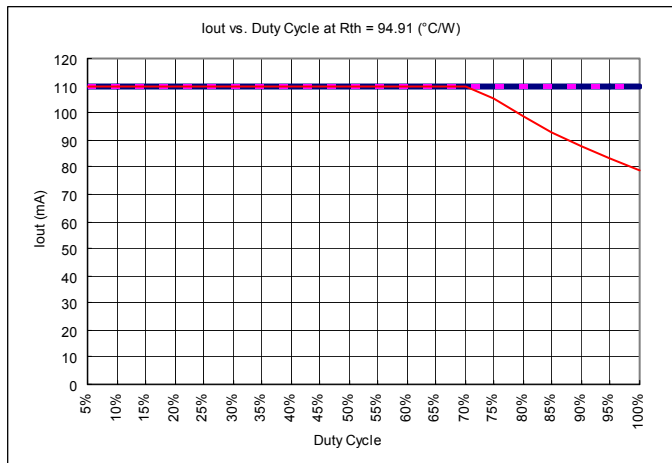

CP\GP Device Type

Condition : $V_{DS} = 1.0\text{V}$, $V_{DD} = 5.0\text{V}$, 8 output channels active, T_a is listed in the legend below.

Device Type		$R_{th(j-a)}$ ($^\circ\text{C/W}$)		Note
CN	GN	64.35	60.20	
CD	GD	85.82	70.14	
CDW	GDW	61.63	68.67	
CP	GP	94.91	80.00	

Load Supply Voltage (V_{LED})

Considering the package power dissipating limits, users had better operate MBI5171 within $V_{DS} = 0.4V \sim 1.0V$. If V_{LED} is higher, for instance, than 5V, V_{DS} may be so high that $P_{D(act)} > P_{D(max)}$, where $V_{DS} = V_{LED} - V_F$. In this case, it is recommended to use as low supply voltage as possible or to arrange a voltage reducer, V_{DROP} . The voltage reducer lets $V_{DS} = (V_{LED} - V_F) - V_{DROP}$. Resistors or Zener diodes can be used as the reducers in the applications as shown in the following figures.

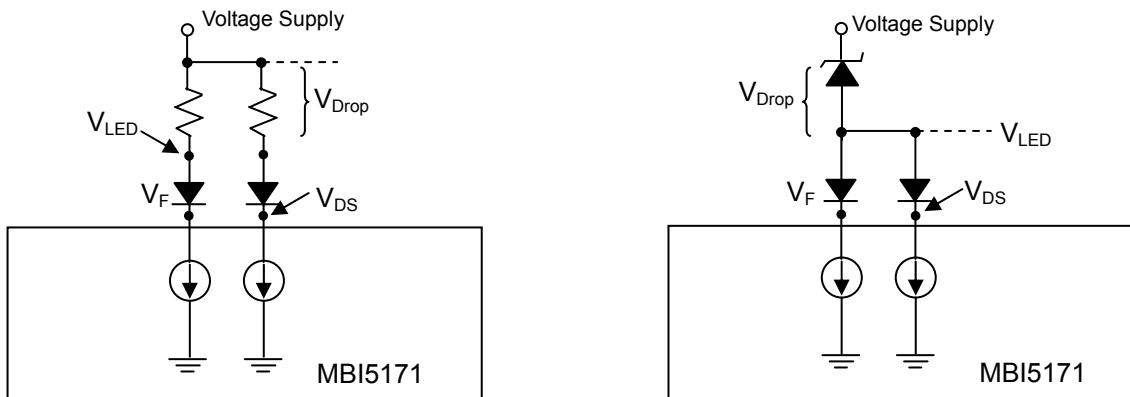

Switching Noise Reduction

LED Driver ICs are frequently used in switch-mode applications which always behave with switching noise due to parasitic inductance on PCB. To eliminate switching noise, refer to "Application Note for 8-bit and 16-bit LED Drivers- Overshoot".

Outline Drawings

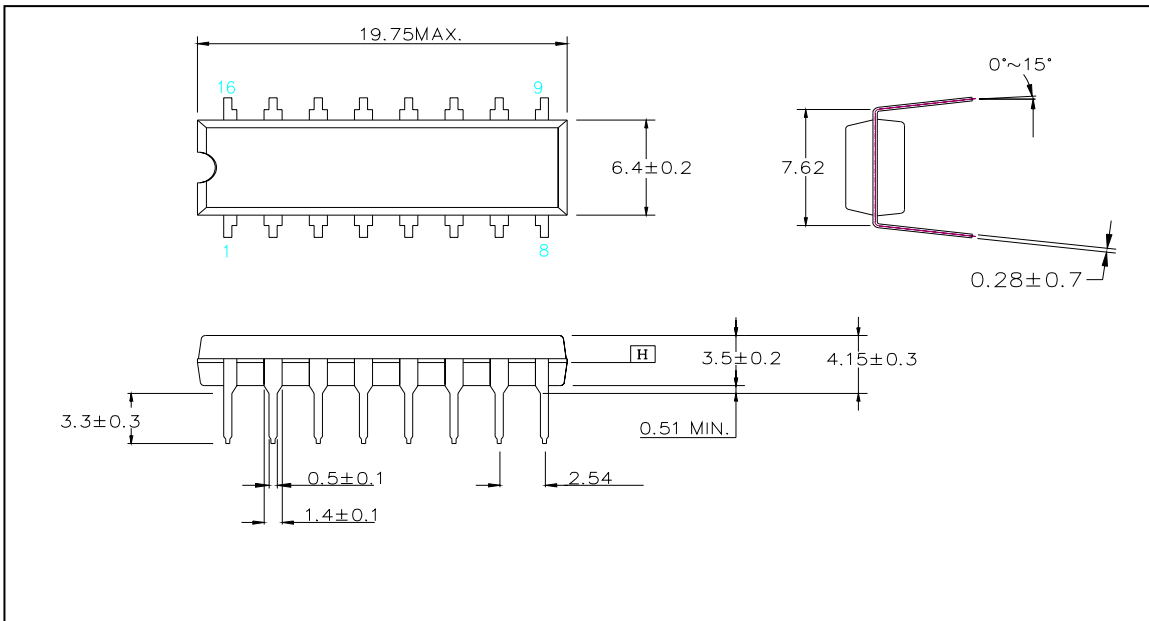

MBI5171CNGN Outline Drawing

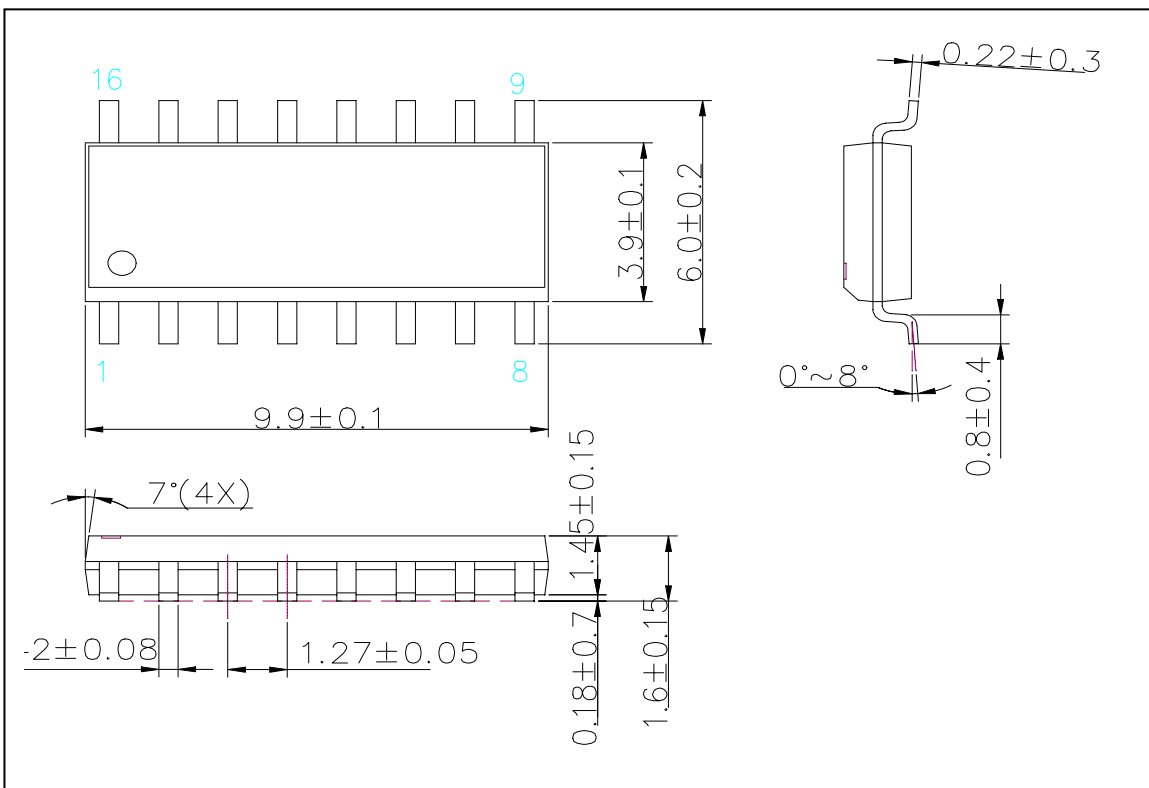

MBI5171CDVGD Outline Drawing

MBI5171

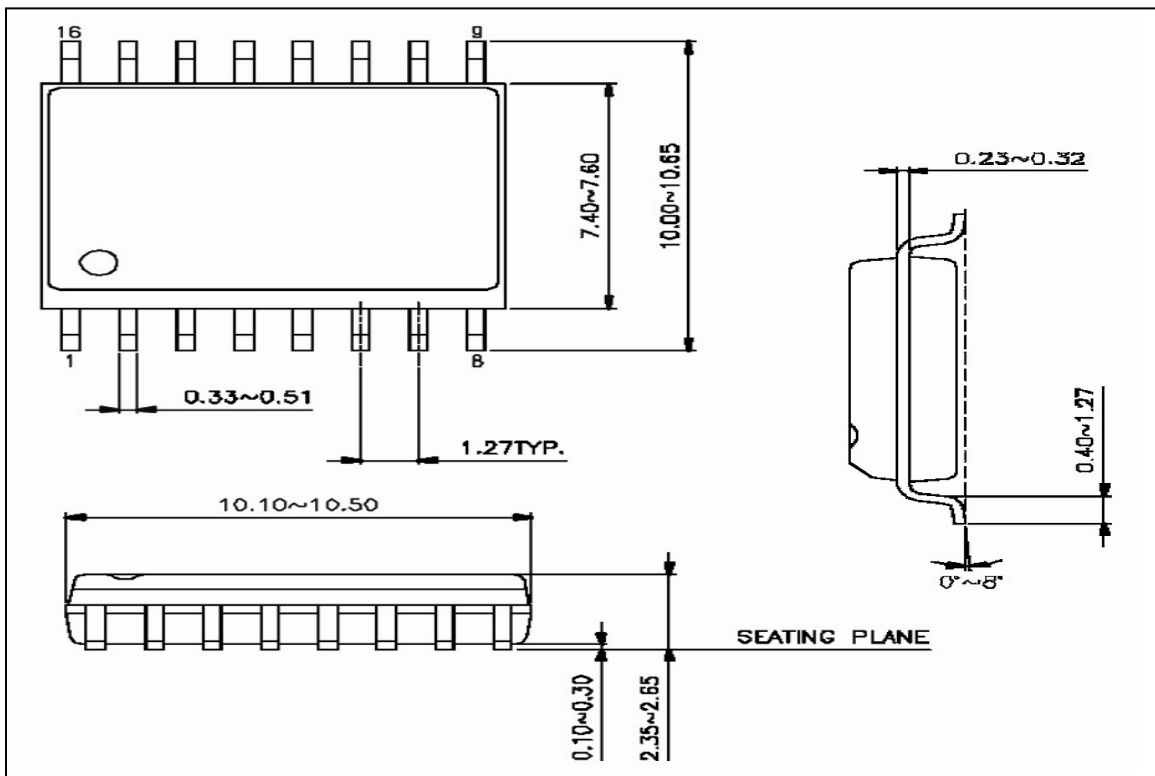

MBI5171CDW/GDW Outline Drawing

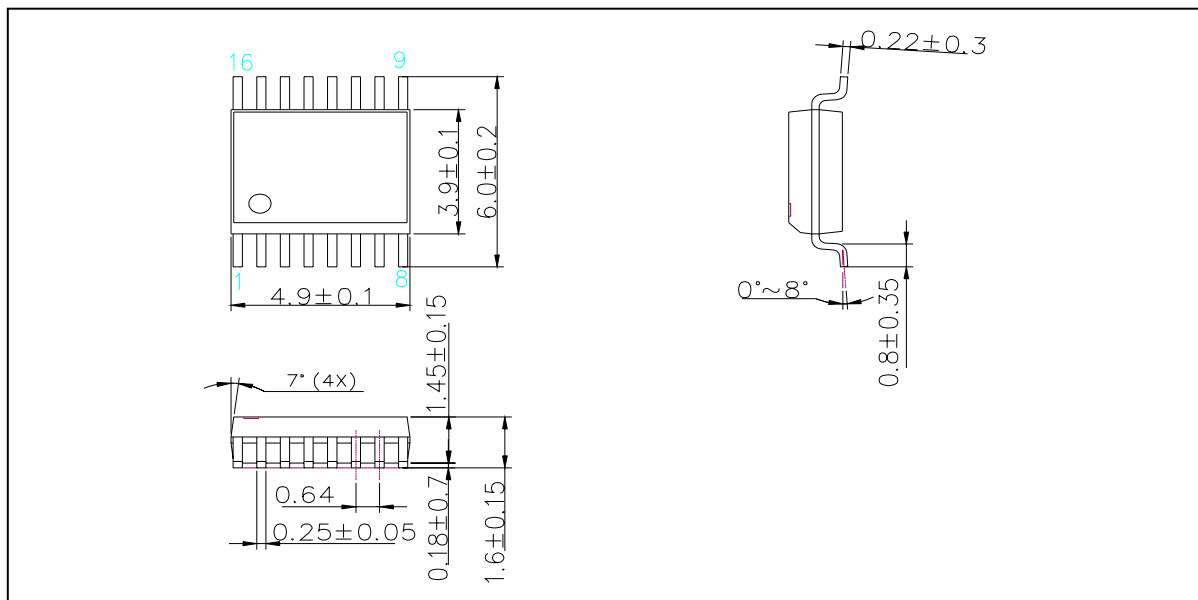

MBI5171CP/GP Outline Drawing

Note: The unit for the outline drawing is mm.

MBI5171

Product Top-mark Information

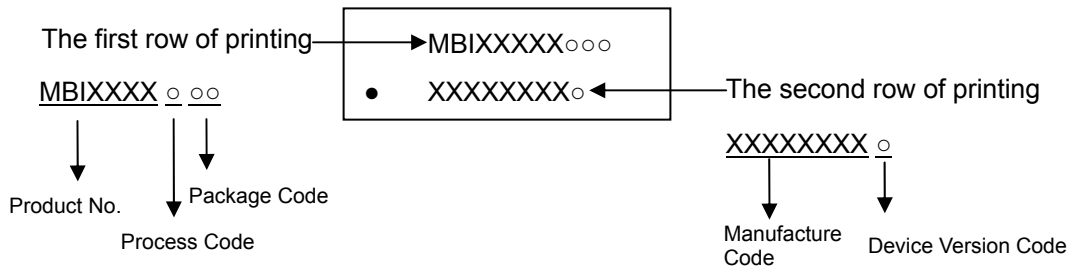

Product Revision History

Datasheet version	Device version code
VA.00	Not defined
VA.02	-

Product Ordering Information

Part Number	Package Type	Weight (g)
MBI5171CN	P-DIP16-300-2.54	1.02
MBI5171CD	SOP16-150-1.27	0.13
MBI5171CDW	SOP16-300-1.27	0.37
MBI5171CP	SSOP16-150-0.64	0.07

Part Number	“Pb-free & Green” Package Type	Weight (g)
MBI5171GN	P-DIP16-300-2.54	1.02
MBI5171GD	SOP16-150-1.27	0.13
MBI5171GDW	SOP16-300-1.27	0.37
MBI5171GP	SSOP16-150-0.64	0.07